

# IPC ICE SLEDGE HOCKEY RULE BOOK



International Paralympic Committee

VERSION 1.5 SEPTEMBER 2009

**INTRODUCTION****SECTION 1 - ELIGIBILITY**

100 - MINIMUM DISABILITY REQUIREMENT .....	10
--	----

**SECTION 2 - FIELD OF PLAY SPECIFICATIONS**

200 - DEFINITION OF THE FIELD OF PLAY.....	12
201 - DIMENSIONS OF THE RINK .....	12
202 - BOARDS .....	12
203 - KICK PLATE .....	12
204 - BENCHES .....	12
ICE RINK .....	13
205 - DOORS .....	14
206 - PROTECTIVE GLASS .....	14
207 - END ZONE NETS .....	15
208 - DIVISION AND MARKING OF THE SURFACE.....	15
209 - GOAL LINES .....	15
210 - BLUE LINES .....	15
211 - CENTER LINE .....	16
212 - FACE-OFF SPOTS AND CIRCLES .....	16
213 - CENTRE FACE-OFF SPOT AND CIRCLE .....	16
214 - FACE-OFF SPOTS IN NEUTRAL ZONE .....	16
215 - END ZONE FACE-OFF SPOTS AND CIRCLE .....	17
216 - REFEREE CREASE .....	17
217 - GOAL CREASE .....	18
218 - GOAL FRAMES, POSTS AND NETTING (GOAL NET) .....	18
219 - TEAM BENCHES .....	19
220 - PENALTY BENCHES .....	20
221 - GOAL JUDGES' BENCH .....	20
222 - SCOREKEEPER'S BENCH.....	20
223 - SIGNAL AND TIMING DEVICES .....	20
224 - SIREN .....	20
225 - CLOCK.....	20
226 - RED AND GREEN LIGHTS .....	21
229 - RINK LIGHTING .....	21

**SECTION 3 - PLAYER EQUIPMENT, CLOTHING, PROTECTIVE EQUIPMENT  
(ACCESSORIES AND FOOT PROTECTION)**

PLAYER EQUIPMENT (MOBILITY DEVICES) .....	22
300 - SLEDGE FRAMES .....	22

301 - HEEL SUPPORT .....	24
302 - FRONT SKID .....	24
303 - FOOT GUARD/ SUPPORT .....	25
304 - FOOT PROTECTION .....	26
305 - SKATE BLADES/ BLADE CARRIER .....	26
306 - SLEDGE SEAT (BUCKET) .....	26
307 - HOCKEY STICK .....	27
308 - PICKS .....	28
CLOTHING .....	28
309 - UNIFORMS .....	28
PROTECTIVE EQUIPMENT (ACCESSORIES AND FOOT PROTECTION) .....	29
310 - HELMET.....	29
311 - FULL FACE MASKS .....	29
312 - GLOVES .....	29
313 - THROAT PROTECTOR .....	30
314 - MOUTH GUARD .....	30
315 - SHIN PROTECTION .....	30
316 - ELBOW PADS .....	30
317 - SHOULDER PADS.....	30
MEASUREMENT TOOLS .....	30
318 - SLEDGE HEIGHT MEASUREMENT TOOL .....	30
319 - PICK MEASUREMENT TOOL .....	31
320 - SLEDGE LENGTH MEASUREMENT STANDARD .....	31

## **SECTION 4 - GOALKEEPER EQUIPMENT (MOBILITY DEVICES), PROTECTIVE CLOTHING, ACCESSORIES AND FOOT PROTECTION**

400 - GOALKEEPER SLEDGE FRAME.....	32
401 - HEEL SUPPORT .....	34
402 - FRONT SKID .....	34
403 - FOOT GUARD/ SUPPORT .....	35
404 - FOOT PROTECTION .....	35
405 - SKATE BLADES/ BLADE CARRIER .....	36
406 - GOALKEEPER SEAT .....	36
407 - GOALKEEPER'S STICKS .....	37
408 - GOALKEEPER'S GLOVES .....	38
409 - BLOCKING GLOVE .....	38
CLOTHING.....	38
410 - GOALKEEPER CLOTHING .....	38
PROTECTIVE EQUIPMENT (ACCESSORIES) .....	39
411 - GOALKEEPER'S HELMET AND FULL FACE MASK .....	39
412 - GOALKEEPER'S LEG GUARDS .....	39
MEASUREMENT TOOLS .....	39

## **SECTION 5 - COMPETITION EQUIPMENT**

501 - Puck .....	40
------------------	----

## **SECTION 6 - GAME FORMAT**

600 - TIMING OF GAME .....	42
601 - START OF GAME AND PERIODS .....	42
602 - TIME-OUT .....	42
603 - DETERMINING THE OUTCOME OF THE GAME .....	43
604 - OVERTIME PERIOD.....	43
605 - GAME WINNING PENALTY SHOTS .....	43

## **SECTION 7 - TEAMS**

700 – TEAM COMPOSITION AND PLAYERS IN UNIFORM .....	46
701 – TEAM CAPTAIN .....	46
702 - ATHLETES ON THE ICE .....	46
703 - SUBSTITUTION OF PLAYERS AND GOALKEEPER'S .....	46
704 - CHANGE OF PLAYERS AND GOALKEEPER'S FROM THE TEAM BENCH DURING PLAY .....	47
705 - CHANGE OF PLAYERS PROCEDURE DURING STOPPAGE OF PLAY .....	47
706 - CHANGE OF PLAYERS FROM THE PENALTY BENCH .....	48
707 - CHANGE OF GOALKEEPER'S DURING STOPPAGE OF PLAY .....	48

## **SECTION 8 - SAFETY**

801 - INJURED PLAYERS .....	50
802 - INJURED GOALKEEPER'S .....	50
803 - PREVENTION OF INFECTIONS .....	50
804 - ICE CLEANING.....	51

## **SECTION 9 - PLAYING RULES**

900 - FACE-OFFS .....	52
901 - FACE-OFF SPOTS AND IMAGINARY LINE .....	52
902 - PROCEDURE FOR CONDUCTING FACE-OFFS .....	53
903 - OFFSIDES .....	54
904 - DELAYED OFFSIDE PROCEDURE .....	55
905 - ICING THE PUCK .....	55
906 - DEFINITION OF A GOAL .....	56
907 - DISALLOWING A GOAL.....	57
908 - GOAL AND ASSIST AWARDED TO THE PLAYER .....	57
909 - PUCK OUT OF BOUNDS .....	58
910 - PUCK ON THE NET .....	58

911 - PUCK OUT OF SIGHT .....58  
 912 - Illegal Puck .....58  
 913 - PUCK STRIKING AN OFFICIAL .....58  
 914 - STOPPING/ PASSING THE PUCK WITH HANDS .....58  
 915 - HIGH STICKING THE PUCK.....59  
 916 - INTERFERENCE BY SPECTATORS.....59

**SECTION 10 - PENALTIES**

1000 - PENALTIES – DEFINITION AND PROCEDURES .....62  
 1001 - MINOR PENALTY.....62  
 1002 - BENCH MINOR PENALTY .....62  
 1003 - MAJOR PENALTY .....64  
 1004 - MISCONDUCT PENALTY .....64  
 1005 - GAME MISCONDUCT PENALTY.....64  
 1006 - MATCH PENALTY .....64  
 1007 - PENALTY SHOT .....65  
 1008 - PENALTY SHOT PROCEDURE .....65  
 1009 - SUPPLEMENTARY DISCIPLINE .....66  
 1010 - GOALKEEPER PENALTY PROCEDURE .....66  
 1011 - COINCIDENTAL PENALTIES .....67  
 1012 - DELAYED PENALTY .....67  
 1013 - CALLING OF PENALTIES.....68  
 FOULS AGAINST PLAYERS .....69  
 1014 - BOARDING .....69  
 1015 - BUTT-ENDING.....69  
 1016 - CHARGING .....70  
 1017 - CHECKING FROM BEHIND .....70  
 1018 - CHECKING TO THE HEAD AND NECK AREA .....71  
 1019 - CROSS-CHECKING .....71  
 1020 - ELBOWING .....71  
 1021 - EXCESSIVE ROUGHNESS.....72  
 1022 - FISTICUFFS OR ROUGHING .....72  
 1023 - HEAD-BUTTING.....73  
 1024 - HIGH STICKING .....73  
 1025 - HOLDING AN OPPONENT .....74  
 1026 - HOLDING THE STICK .....74  
 1027 - HOOKING .....74  
 1028 - INTERFERENCE .....75  
 1029 - SLASHING.....75  
 1030 - SPEARING.....76  
 1031 - TEEING .....76  
 OTHER PENALTIES.....77  
 1032 - ABUSE OF OFFICIAL AND UNSPORTSMANLIKE CONDUCT BY PLAYERS .....77

1033 - ABUSE OF OFFICIALS AND UNSPORTSMANLIKE CONDUCT BY TEAM OFFICIALS .....	78
1034 - BROKEN STICK .....	79
1035 - CAPTAIN AND ALTERNATE CAPTAIN COMPLAINT .....	80
1036 - DELAY OF GAME – ADJUSTMENT OF EQUIPMENT .....	80
1037 - DELAY OF GAME – DISPLACING THE GOAL FRAME .....	80
1038 - DELAY OF GAME – INJURED PLAYER REFUSING TO LEAVE THE ICE .....	81
1039 - DELAY OF GAME – KEEPING THE PUCK IN MOTION .....	81
1040 - DELAY OF GAME – LATE LINE UP .....	81
1041 - DELAY OF GAME – MORE THAN ONE CHANGE AFTER GOAL SCORED .....	81
1042 - DELAY OF GAME – SHOOTING OR THROWING THE PUCK OUTSIDE THE PLAYING AREA .....	81
1043 - DELAY OF GAME – VIOLATION OF FACE-OFF PROCEDURES .....	82
1044 - DIVING .....	82
1045 - ILLEGAL OR DANGEROUS EQUIPMENT .....	82
1046 - FALLING ON THE PUCK BY A PLAYER .....	83
1047 - FALLING ON THE PUCK BY A GOALKEEPER .....	83
1048 - HANDLING THE PUCK WITH HANDS BY A PLAYER .....	84
1049 - HANDLING THE PUCK WITH HANDS BY A GOALKEEPER .....	85
1050 - INFRINGEMENT OF CHANGE OF PLAYERS PROCEDURE .....	86
1051 - INTERFERENCE WITH SPECTATORS .....	86
1052 - PLAYERS LEAVING THE PENALTY OR PLAYER’S BENCH .....	86
1053 - PLAYERS LEAVING THE PENALTY BENCH .....	86
1054 - PLAYERS LEAVING THE BENCHES DURING AN ALTERCATION .....	87
1055 - PREVENTION OF INFECTIONS BY BLOOD .....	87
1056 - TEAM OFFICIALS LEAVING THE PLAYER’S BENCH .....	87
1057 - REFUSING TO START PLAY – TEAM ON THE ICE .....	88
1058 - REFUSING TO START PLAY - TEAM NOT ON THE ICE .....	88
1059 - THROWING A STICK OR ANY OBJECT OUT OF THE PLAYING AREA .....	88
1060 - THROWING A STICK OR ANY OBJECT WITHIN THE PLAYING AREA .....	88
1061 - THROWING A STICK OR ANY OBJECT ON A BREAKAWAY SITUATION .....	89
1062 - TOO MANY PLAYERS ON THE ICE .....	89
1063 - PENALTIES FOR GOALKEEPER’S .....	90
1064 - GOALKEEPER BEYOND THE CENTER RED LINE .....	90
1065 - GOALKEEPER GOING TO THE PLAYER’S BENCH DURING STOPPAGE OF PLAY .....	90
1066 - GOALKEEPER LEAVING THE CREASE DURING AN ALTERCATION .....	90
1067 - GOALKEEPER DROPPING THE PUCK ON THE GOAL NETTING .....	90
1068 - PROTECTION OF GOALKEEPER .....	91

## SECTION 11 - REFEREES AND LINESMEN SIGNALS

REFEREE SIGNALS .....	92
BOARDING - RULE 1014 .....	92
BUTT-ENDING - RULE 1015 .....	92
PLAYER CHANGE SIGNAL - RULE 705 .....	92
CHARGING - RULE 1016 .....	92
CHECKING FROM BEHIND - RULE 1017 .....	93

CROSS-CHECKING - RULE 1019 .....	93
DELAYED CALLING OF PENALTY - RULE 1012.....	93
ELBOWING - RULE 1020 .....	93
PUCK IN THE NET - RULE 906 .....	94
HAND PASS - RULE 914 .....	94
HIGH STICKING - RULE 1024 .....	94
HOLDING - RULE 1025.....	94
HOLDING THE STICK - RULE 1026 .....	95
HOOKING - RULE 1027 .....	95
INTERFERENCE - RULE 1028.....	95
MATCH PENALTY - RULE 1006 .....	95
MISCONDUCT PENALTY - RULES 1004, 1005.....	96
PENALTY SHOT - RULE 1008 .....	96
ROUGHING - RULE 1022.....	96
SLASHING - RULE 1029.....	96
SPEARING - RULE 1030.....	97
TEEING - RULE 1031 .....	97
TIME OUT - RULE 602 .....	97
TOO MANY PLAYERS ON THE ICE - RULE 1062 .....	97
CHECKING TO THE HEAD AND NECK AREA - RULE 1018 .....	98
WASH OUT.....	98
LINESMAN'S SIGNALS .....	98
DELAYED OFFSIDE - RULE 904.....	98
ICING THE PUCK - RULE 905 .....	98
OFFSIDE CALL - RULE 903.....	99
<b>ANNEX 1 - ILLUSTRATION OF GOAL FRAME .....</b>	<b>100</b>
<b>ANNEX 2 - MAJOR RULE DIFFERENCES .....</b>	<b>100</b>
OVERVIEW .....	100
A 2.1 - RULE DIFFERENCES.....	100
A 2.2 - POSITIONING, PROCEDURES AND JUDGEMENT .....	101
<b>ANNEX 3 - PROTECTIVE EQUIPMENT .....</b>	<b>103</b>
INDEX .....	104

## INTRODUCTION

---

This Rule book contains the Rules for IPC Ice Sledge Hockey Sport. Specific sections of the IPC Handbook complement these rules and the general activities of the sport.

1. IPC Code of Ethics

The complete IPC Code of Ethics is chapter 1.1 in the IPC Handbook and can be accessed at the following link:

[http://www.paralympic.org/release/Main Sections Menu/IPC/IPC Handbook/Section 2/Section ii chapter 1.1 IPC Code of Ethics.pdf](http://www.paralympic.org/release/Main%20Sections%20Menu/IPC/IPC%20Handbook/Section%202/Section%20ii%20chapter%201.1%20IPC%20Code%20of%20Ethics.pdf)

2. Athlete Nationality

IPC Policies regarding Athlete Nationality will apply and can be found in the IPC Handbook Section 3.1:

[http://www.paralympic.org/release/Main Sections Menu/IPC/IPC Handbook/Section 2/Section ii chapter 3.1 Athlete Nationality Policy.pdf](http://www.paralympic.org/release/Main%20Sections%20Menu/IPC/IPC%20Handbook/Section%203/Section%20ii%20chapter%203.1%20Athlete%20Nationality%20Policy.pdf)

3. IPC Anti-doping Code

This Code will apply to those competitions using IPC Ice Sledge Hockey Rules where Anti-Doping controls are implemented. The complete reference can be found in the IPC Handbook Section 1.2 and in the link:

[http://www.paralympic.org/release/Main Sections Menu/Anti Doping/2006 06 IPC Anti-Doping Code - January 2004 - Revised.pdf](http://www.paralympic.org/release/Main%20Sections%20Menu/Anti%20Doping/2006%2006%20IPC%20Anti-Doping%20Code%20-%20January%202004%20-%20Revised.pdf)



## SECTION 1 - ELIGIBILITY

Eligible for competition are all athletes with locomotor disabilities in the lower part of the body as defined below.

### 100 - MINIMUM DISABILITY REQUIREMENT

Main principle: The athlete must have an impairment of permanent nature in the lower part of the body of such a degree that it,

1. is obvious and easily recognizable
2. makes ordinary skating - and consequently standing ice hockey playing impossible.  
Interpretation of regain principle:

Minimum disability is regarding.

**Amputation** - through the ankle

**Paresis** - loss of 10 muscle points in both legs (not counting grade 1 and 2; maximal point score 80)

**Joint mobility** - ankylosis (fusion) of ankle joint  
- extension defect of at least 30 degrees or ankylosis of knee joint

**CP** - spasticity/dyscoordination corresponding to CP class 7

**Leg shortening** - at least 7 centimeters

Note:

1. Normal upper body function is expected. Any impairment in upper body does not affect requirements of minimum disability in lower body.
2. Persons with hip joint disorders only, i.e. restricted mobility, are not expected to participate in Ice Sledge Hockey and are not eligible.
3. Persons without required minimum disability -but who cannot play regular ice hockey because of chronic post traumatic painful disorders, instability of ankle or knee joints or similar conditions are not eligible.



## SECTION 2 - FIELD OF PLAY SPECIFICATIONS

### 200 - DEFINITION OF THE FIELD OF PLAY

The game of ice sledge hockey shall be played on a white ice surface known as a **RINK**.

### 201 - DIMENSIONS OF THE RINK

Maximum size: **61m long** by **30m wide**.

Minimum size: **56m long** by **26m wide**.

The corners shall be rounded in the arc of a circle with a radius of **7 to 8.5m**.

### 202 - BOARDS

The rink shall be surrounded by a wooden or plastic wall known as the «**BOARDS**», which shall be white in colour.

They shall be not less than **1.17m** and not more than **1.22m** in height above the level of the ice surface.

The boards shall be constructed in such a manner that the surface facing the ice shall be smooth and free of any obstruction that could cause injury to the players, and the protective screens and gear used to hold the boards in position shall be mounted on the side away from the playing surface.

The gaps between the panels shall be minimized to **3mm**.

### 203 - KICK PLATE

At the lower part of the boards will be fixed a «**KICK PLATE**», **yellow** in colour, **15 to 25cm** in height.

### 204 - BENCHES

Team benches and penalty boxes must have plexiglass in front, the team benches must have two doors with level access to the ice surface. Allowing the athletes entrance and egress without assistance or lifting by support staff. The penalty boxes should have level access also. Additionally, the surfaces inside these off-ice areas should be covered with **plastic ice** or other material to avoid damage to sledge blades. Any structural supports protruding must be securely padded or protected to avoid damage or injury.

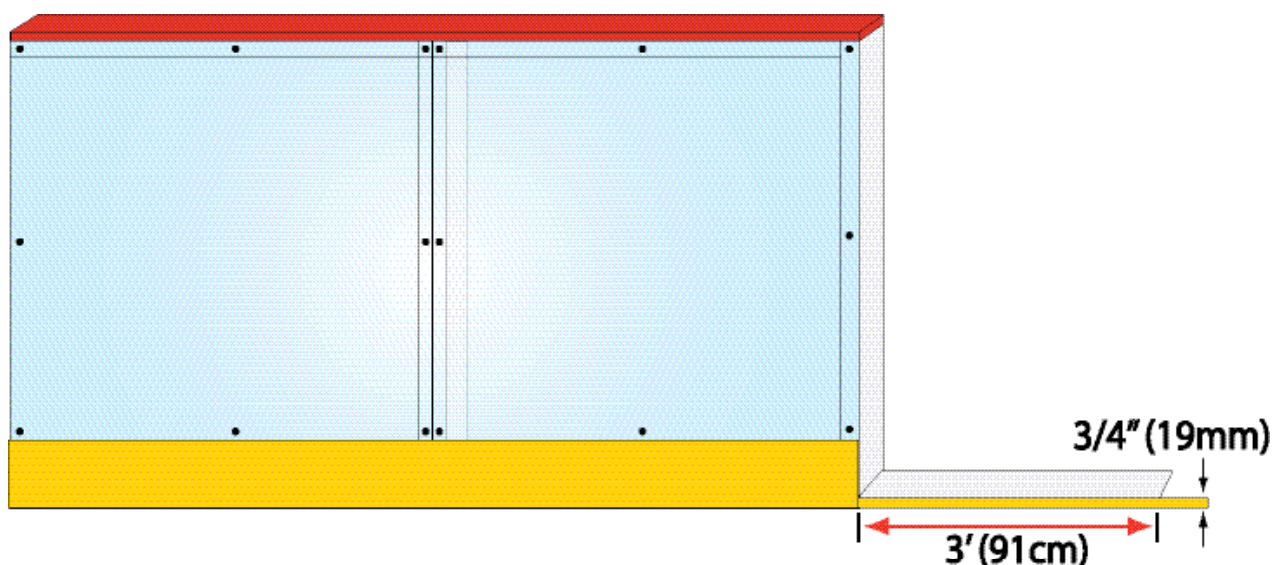

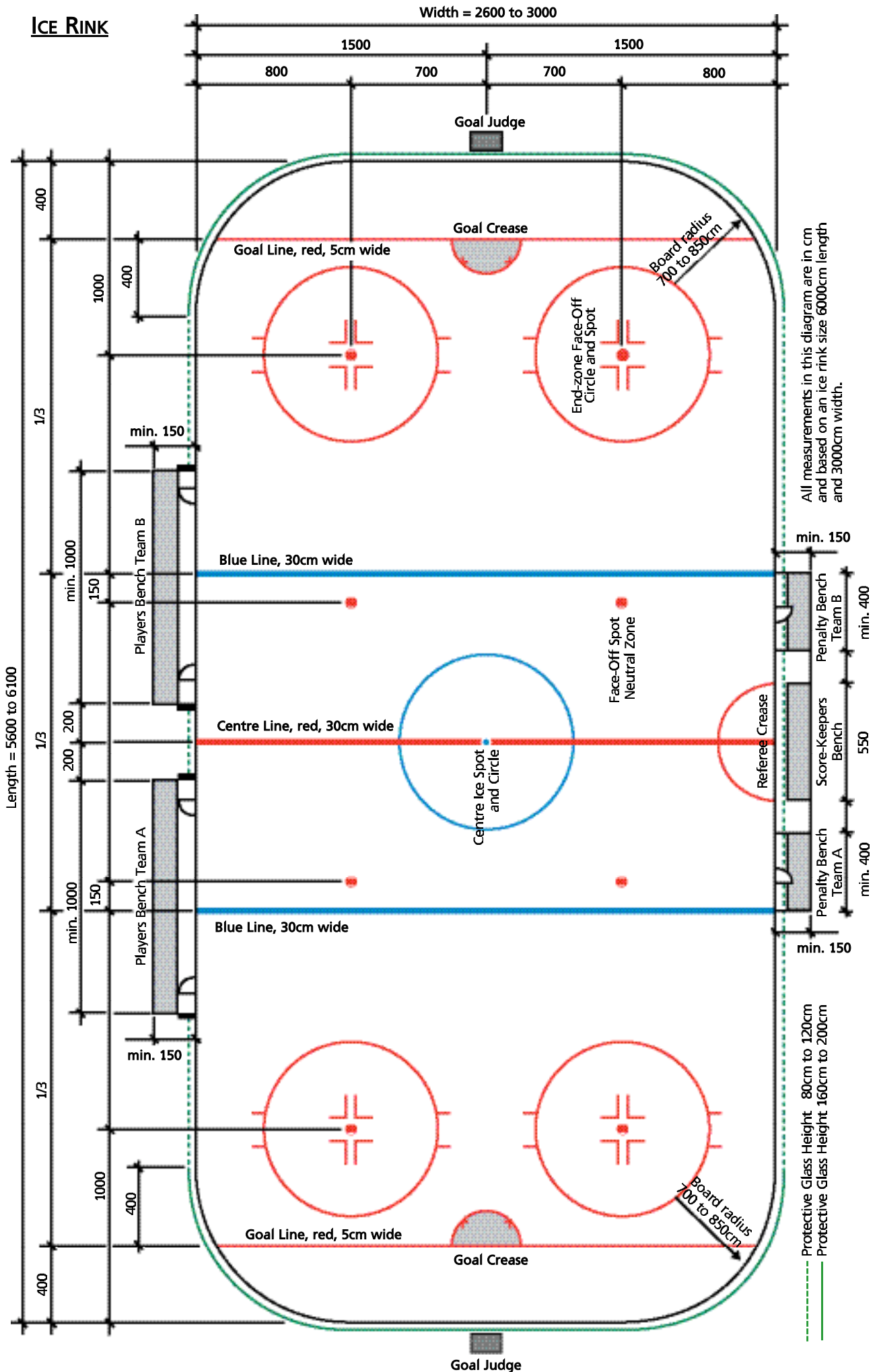

**205 - DOORS**

- a) All doors giving access to the ice surface must swing away from the ice surface.
- b) The gaps between the door and the board shall be minimized to **5mm**.

**206 - PROTECTIVE GLASS**

- a) The protective glass located above the boards shall be **160cm to 200cm** in height on the ends and shall extend **4m** from the goal line towards the neutral zone, and not less than **80cm** in height along the sides, except in front of the team benches.
- b) The gaps between the glass panels shall be minimized to **5mm**.
- c) At any interruption of the protective glass there shall be protective padding to prevent the injury of the players.
- d) No openings are allowed in the protective glass. In case of advertising allowed on the boards, the lines shall at least be marked on the kick plate. The entire width of the line shall be considered as part of the zone that the puck is in.

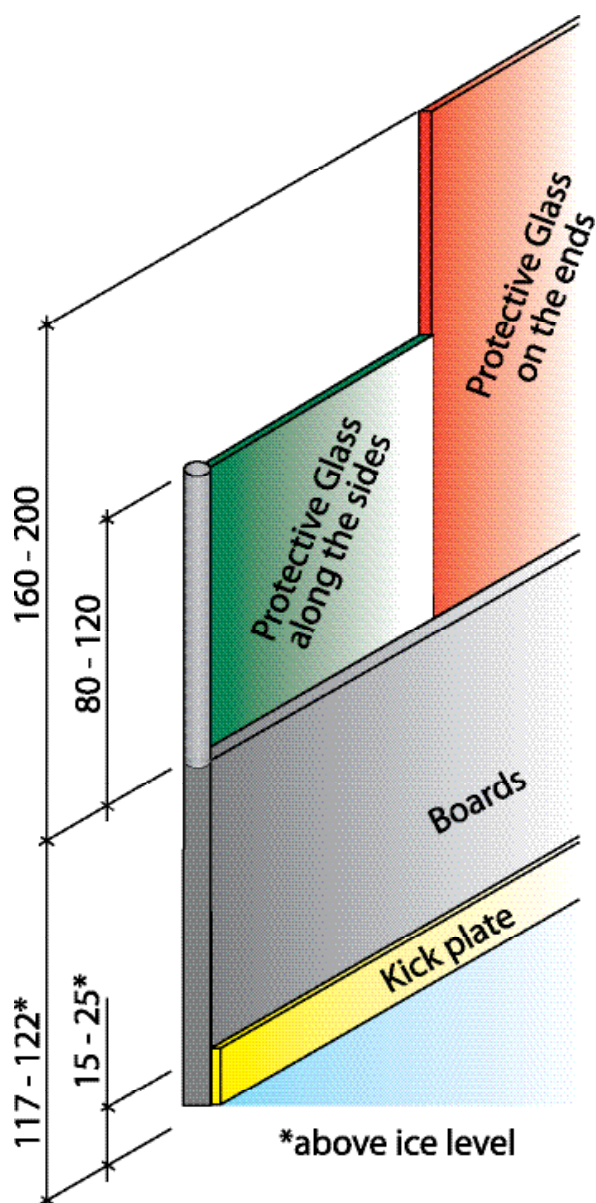

**207 - END ZONE NETS**

Protective nets must be suspended above the end zone boards and glass.

**208 - DIVISION AND MARKING OF THE SURFACE**

The ice surface will be divided in its length by five lines marked on the ice and extending completely across the rink and continuing vertically up the side of the boards.

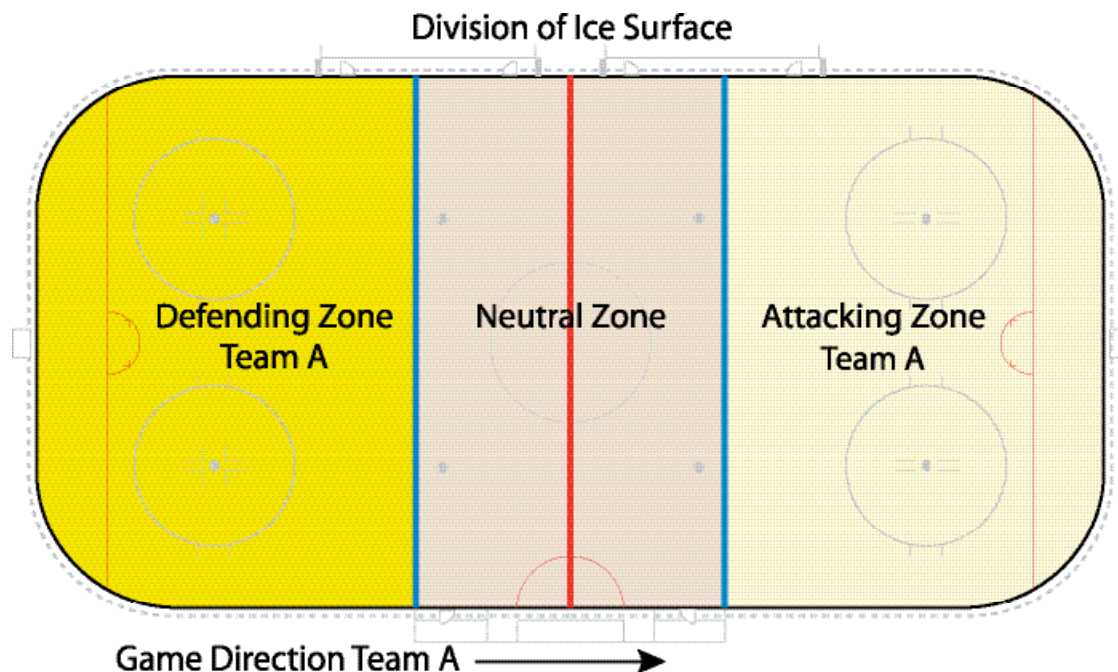
**209 - GOAL LINES**

Lines shall be marked 4m from each end of the rink, 5cm wide and red in colour, known as the:

**GOAL LINES****210 - BLUE LINES**

The ice area between the two goal lines shall be divided in three equal parts by lines 30cm wide and blue in colour known as the:

**BLUE LINES**

These lines will determine the three Zones, defined as follows:

For one team, the zone in which their goal is situated is the:

**DEFENDING ZONE**

The central zone is the:

**NEUTRAL ZONE**

The farthest zone is the:

**ATTACKING ZONE**

**211 - CENTER LINE**

A line known as the **Centre LINE** shall be located in the middle of the rink. It shall be **30cm** wide and **red** in colour.

**212 - FACE-OFF SPOTS AND CIRCLES**

All spots and circles are marked on the ice surface in order to position the players for a face-off as ordered by the officials at the beginning of the game, at the beginning of each period and after each stoppage of play.

**213 - CENTRE FACE-OFF SPOT AND CIRCLE**

A circular blue spot, **30cm** in diameter, shall be marked exactly in the Centre of the rink. With this spot as a Centre, a circle with a radius of **4.5m** shall be marked with a blue line **5cm** wide.

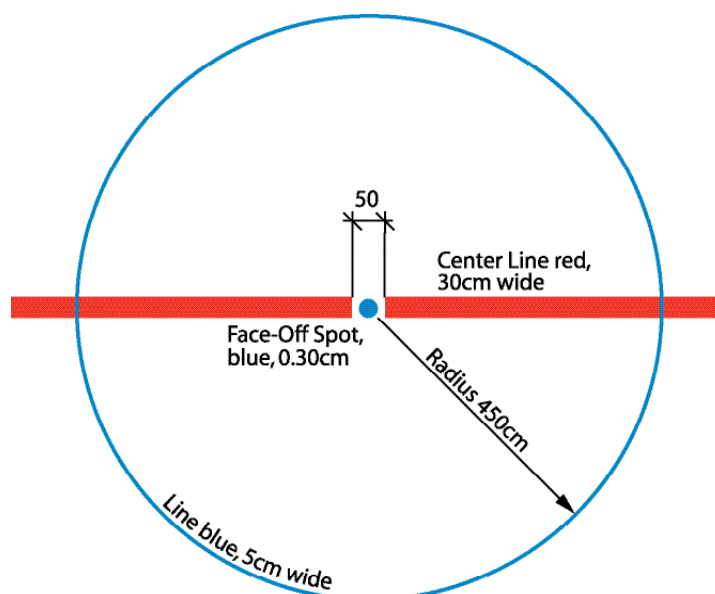
**214 - FACE-OFF SPOTS IN NEUTRAL ZONE**

Two **red** spots, **60cm** in diameter, shall be marked in the neutral zone, **1.5m** from each blue line as illustrated on the opposite page.

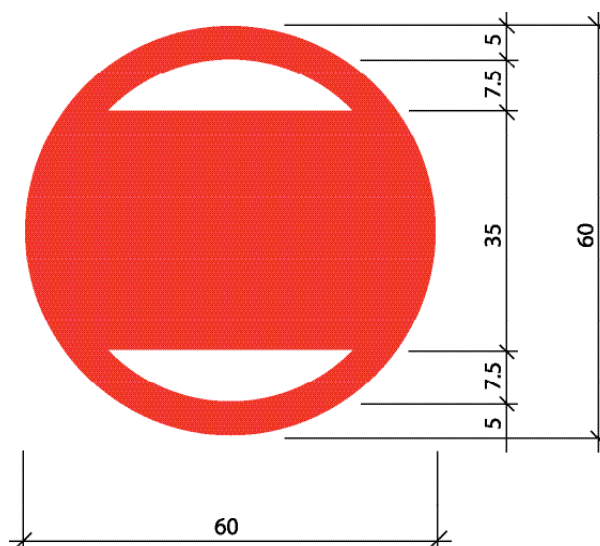

**215 - END ZONE FACE-OFF SPOTS AND CIRCLE**

- a) Face-off spots and circles shall be marked on the ice in both end zones and on both sides of each goal as illustrated.
- b) The face-off spots will be **60cm** in diameter, **red** in colour, as illustrated.
- c) On opposite sides of the end zone face-off spots shall be marked double "L", as illustrated above.
- d) The circles will have a radius of **4.5m** from the Centre of the face-off spots and marked with a red line, **5cm** wide.

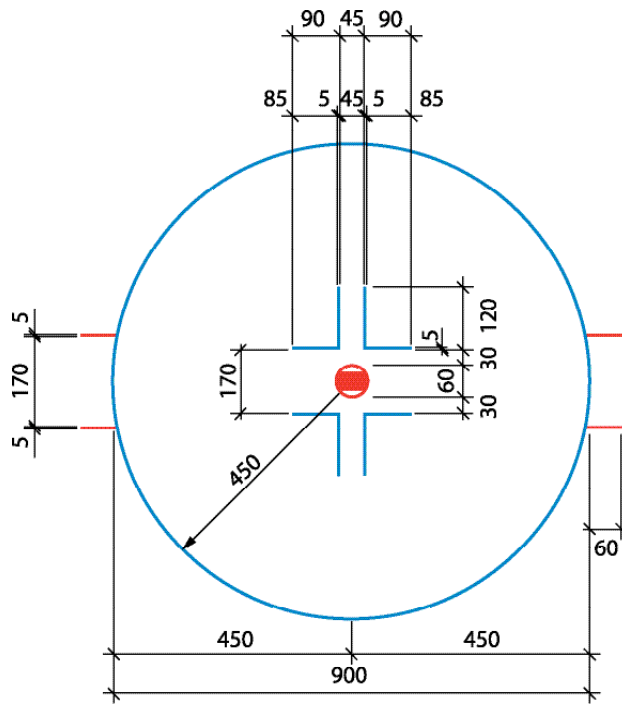

**216 - REFEREE CREASE**

An area known as the **REFEREE CREASE** shall be marked on the ice in a semi-circle by a red line, **5cm** wide, and with a radius of **3m**, immediately in front of the Score-Keepers Bench, as illustrated.

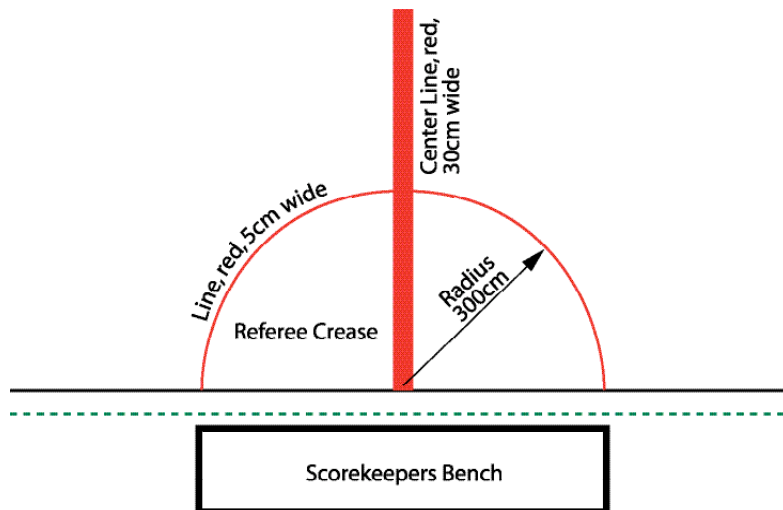

**217 - GOAL CREASE**

- In front of each goal a **GOAL CREASE** area shall be marked by a red line, **5cm** wide, as illustrated.
- The goal crease area shall be painted **light blue**. The inside of the goal area from the goal line to the back of the net shall be white.
- The goal crease shall include all the space outlined by and include the crease line and extending vertically **1.27m** to the top of the goal frame.
- The goal crease shall be laid out as follows: A semi-circle **180cm** in radius and **5cm** in width shall be drawn using the centre of the goal as the centre point. In addition, an "L" shaped marking of **15cm** in length and **5cm** in width (both lines) at each front corner shall be painted on the ice. The location of the "L" marking is measured by drawing an imaginary line **122cm** from the goal line to the edge of the semi-circle. At that point, the "L" marking shall be drawn.

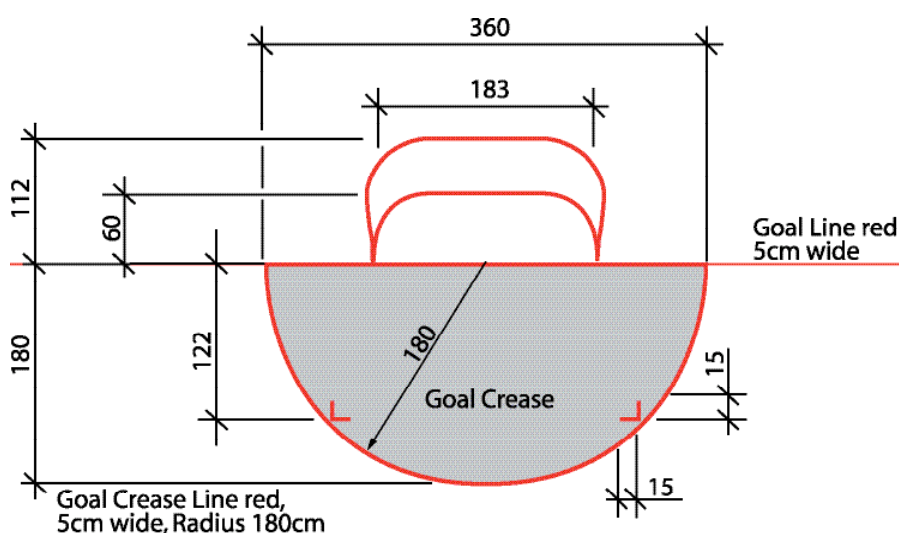
**218 - GOAL FRAMES, POSTS AND NETTING (GOAL NET)**

- The goal nets shall be located in the centre of the goal lines.
- The goal posts shall extend vertically **1.22m** above the ice surface and be **1.83m** apart (internal measurements). The goal posts and horizontal crossbar that form the tubular steel frame shall be of a specified design with an external diameter of **5cm** and shall be painted **red**.
- The goals and crossbar shall be completed by a frame supporting the netting, the deepest point of which shall not be more than **1.12m** or less than **0.60m**. It shall be painted white, except for the exterior part of the base frame, which shall be painted **red**.
- A netting of white nylon cord shall be draped over to enclose the back of the goal frame in such a manner as to prevent the puck from coming to rest on the outside of it, yet strung in a manner that shall keep the puck inside the goal net.

- e) The inside of the supports, other than the goal posts and crossbar, shall be covered by a white padding. The padding of the base frame shall start not less than **10cm** from the goal posts and shall be attached in a manner that shall not restrict the puck from completely crossing the goal line.

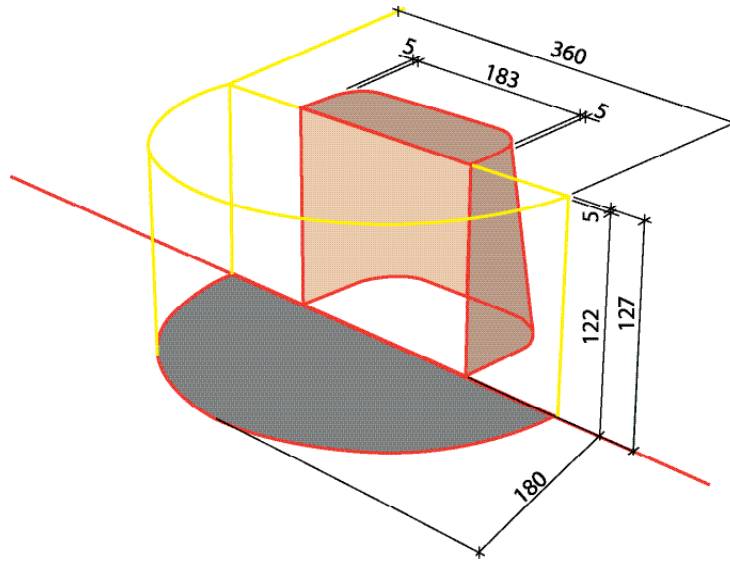

**219 - TEAM BENCHES**

Each rink shall be provided with two identical benches, exclusively for the use of players/Goalkeeper's in uniform and officials of both teams. The team benches shall be on the same side of the rink, immediately along the ice but opposite to the penalty benches, separated by a substantial distance or by other facilities, and convenient to the dressing rooms. Each team bench shall begin **2m** from the centre line with a minimum length of **10m** and a minimum width of **1.5m**.

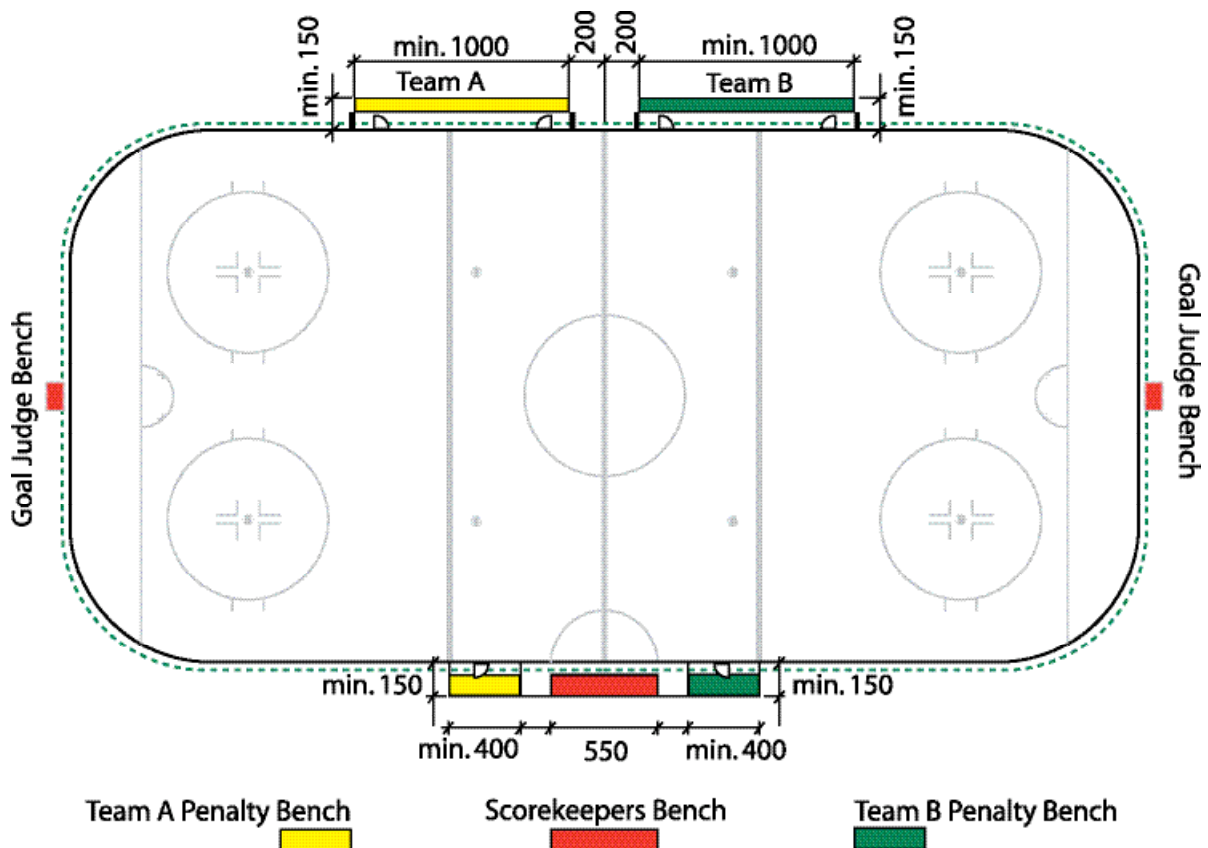

Each team bench shall accommodate: **15 players** in sledges and **6 team officials**.

Each team bench must have two doors, one of which must be in the **NEUTRAL ZONE**. Each team bench must be protected from access by persons other than the players and the six team officials.

### **220 - PENALTY BENCHES**

Each rink shall be provided with two benches to be known as the penalty benches for a minimum of **4** players each. They shall be located on both sides of the Scorekeeper's desk and opposite to the team benches and shall have a minimum length of **4m** and a minimum width of **1.5m**. Access to the penalty benches shall be restricted to persons other than the penalized players and the penalty bench attendants.

### **221 - GOAL JUDGES' BENCH**

Properly protected cages to eliminate interference with the Goal Judge's activities shall be placed at each end of the rink behind the board and glass in the area of the goal.

### **222 - SCOREKEEPER'S BENCH**

Between the penalty benches will be located the Scorekeeper's bench which shall have a length of **5.5m** to accommodate **6 officials**.

### **223 - SIGNAL AND TIMING DEVICES**

#### **224 - SIREN**

Each rink shall be provided with a siren or other suitable sound device to be used by the Timekeeper.

#### **225 - CLOCK**

Each rink shall have an electric clock (scoreboard) in order to provide spectators, players and officials with accurately information concerning:

1. Names of both teams
2. Time played in any given period, counting up in minutes and seconds from 0.00 to 15.00,
3. Penalty time remaining to be served for at least two players on each team counting down from the total number of minutes to 0,
4. Score
5. Time-outs, counting down from 30 to 0 seconds,
6. Intermission time, counting down from 15 to 0 minutes.

Electronic scoreboards with video text are recommended for IPC competitions.

JAPAN		HOME	GUEST	ESTONIA	
PLAYER	PENALTY	03	03	PLAYER	PENALTY
19	— 4.27	T.O.	T.O.	06	— 3.45
11	— 1.53	1	1	22	— 1.53
04	— 2.00	20:00		30	— 5.00
17	— 1.07			17	— 0.47
20	— 0.14			20	— 0.54

### 226 - RED AND GREEN LIGHTS

Behind each goal there shall be: A red light to be lit by the Goal Judge when a goal is scored, A green light to be lit automatically by the electric clock when the Timekeeper stops the clock and at the end of each period.

1. The red light shall be connected to the timing device in such a manner so that, when the period has ended, it would be impossible for the Goal Judge to turn it on.
2. At the end of a period, the fact that the Goal Judge is not be able to turn on the red light on does not necessarily mean that a goal is not valid. The determining factor is whether or not the puck is completely over the goal line and in the goal before the period ends.
3. The purpose of the green light is to enable the Referee and Linesmen to observe the goal and light in the same sight line and know exactly when the period ends.

### 229 - RINK LIGHTING

All rinks shall be sufficiently well illuminated in accordance with the standards stipulated in the technical requirements for the specified/respective competition.

1. If, there is not sufficient light to continue the game, the referee shall have the authority to postpone the remainder of the game or taking time-out, pending improvement of the lighting situation.
2. If one team is disadvantaged to a greater extent by the failure of lights, and in the opinion of the Referee in consultation with the technical delegate, the game should not be cancelled; the teams will alternate ends of the rink and play the same amount of time in each end of the rink.
3. If in the opinion of the referee in consultation with the technical delegate the failure of lighting does not result in a greater disadvantage to one team, play will resume.

## SECTION 3 - PLAYER EQUIPMENT, CLOTHING, PROTECTIVE EQUIPMENT (ACCESSORIES AND FOOT PROTECTION)

### Note:

The IPC Ice Sledge Hockey Sport Technical Committee may conduct equipment verification to ensure equipment adheres to the rules. The IPC ISH STC reserves the right to conduct equipment verification at anytime throughout the competition including, but not limited to pre-competition training.

All protective equipment, clothing, accessories and footwear must meet generally accepted standards for ice hockey. It is the responsibility of the player to ensure that the equipment used conforms, where specified to the official playing rules.

All equipment used by the athletes must be in compliance with the IPC uniform and trademark guidelines as stipulated in the IPC Sport Regulations Advertising. The IPC ISH STC (International Paralympic Committee Ice Sledge Hockey Sport Technical Committee), adheres to HECC (Hockey Equipment Certification Council) as the governing body on the approval of all hockey helmets and facial protection, for Players and Goalkeeper's.

For any current and updated lists refer to the HECC web site:

[www.hecc.org](http://www.hecc.org)

The equipment listed in [Annex 3](#) is a current list of IPC ISH STC recognized players equipment.

### PLAYER EQUIPMENT (MOBILITY DEVICES)

Player Equipment shall be defined as the sledge, bucket, skate holder, skate blade, sticks and picks.

#### 300 - SLEDGE FRAMES

- a) Sledge frames may be constructed of the following approved material: Steel, aluminum, titanium and magnesium. The Material must be cylindrical and not have a diameter smaller than **1.5cm** or greater than **3cm**.
- b) The frames main side rails shall be **15cm MINIMUM** width (**measured from the out side of the frame**) and a maximum width no greater than the seat of the sled. The side rails of the frame may taper underneath the seat to accommodate the blades; any taper must **NOT** exceed **45 degrees**.

No more than **1cm** of the frame may protrude beyond the rear of the seat.

The blade carrier may sit on the rear end of the frame, however the frame must protrude **1cm** beyond the end of the blade.

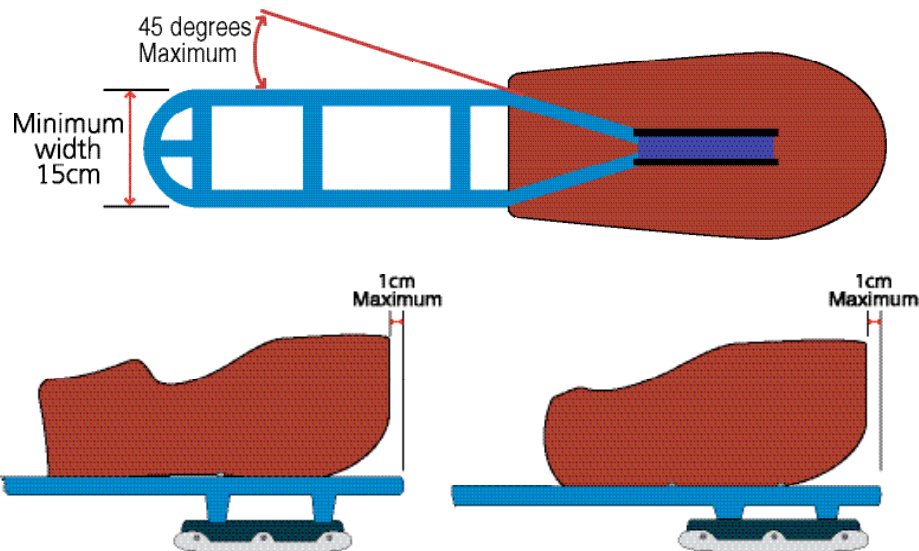

- c) The front of the sledge shall have a continuous curve with a maximum radius **one half (1/2)** of the inside width of the frame at its widest point forward of the seat.

The following materials may be used in constructing this piece: Steel; Aluminum; Titanium; Magnesium, Polyurethane.

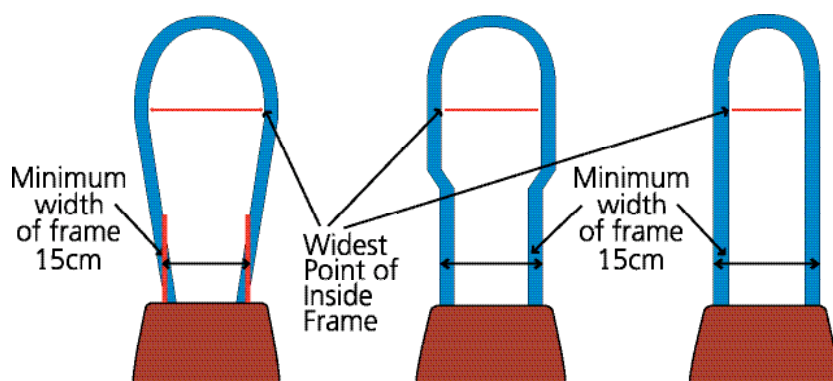

- d) The frame may be fitted with a maximum of **(4)** four cross members, and one foot rail, mounted forward of the seat. The cross members may be square or cylindrical and not have a diameter smaller than **1.5cm** or greater than **3cm**.

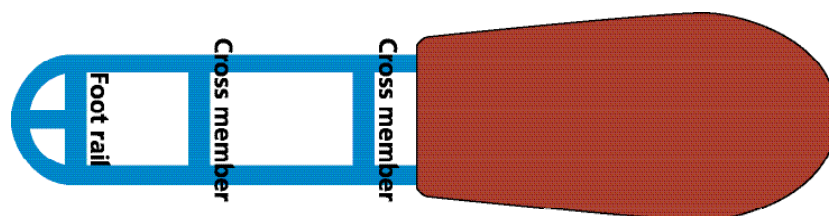

- e) The height of the main frame measured from the ice to the bottom of the frame shall be **8.5cm minimum - 9.5cm maximum**.

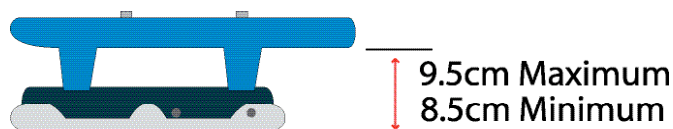

- f) Players seats/buckets may sit on the ice hockey blades/ blade carrier, as long as it is not below **5cm**.

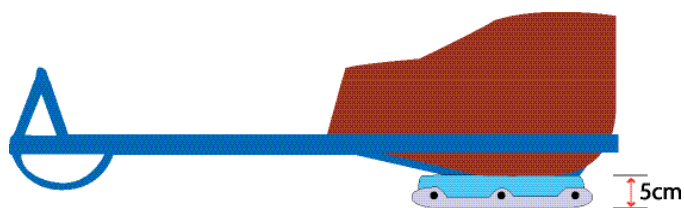

- g) For a double amputee minimum Length of the frame must be:
1. **80cm**.
  2. Accommodate the required **minimum 10cm** length of the front skid.

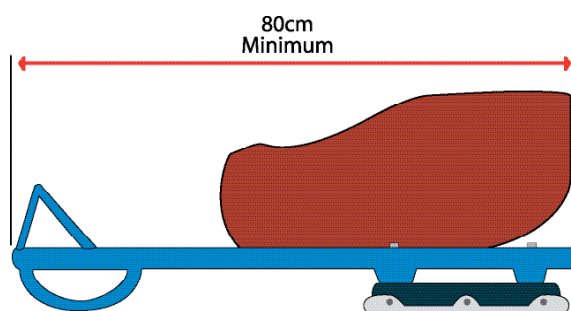

### 301 - HEEL SUPPORT

Each Sledge may have a heel support with a maximum width of **10cm**. If the player is a single amputee, a second support may be used for the stump (**maximum width of 10cm**). No part of the stump may hang below the frame.

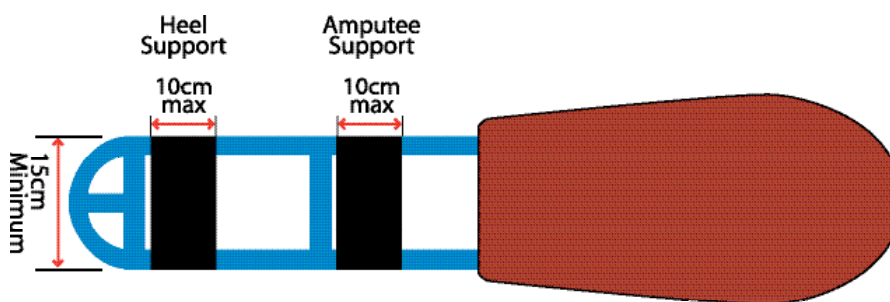

### 302 - FRONT SKID

The Sledge must have one skid. The front skid must be attached to the frame not more than **3cm** from the front of the main frame. The skid must be mounted in the Centre of the frame and extend backwards **10cm minimum** and **20cm maximum**. The skid measured from the frame downward towards the ice must be no less than **7cm minimum** and **9.5cm maximum**.

- The skid may be made of the same material as the main frame. If made of the same material, it must be cylindrical and have a diameter of not less than **1.5cm minimum** and **3cm maximum**.
- The skid may be designed of a nylon/plastic material. It may be solid in shape and have a width of not less than **1.5cm minimum** and **3cm maximum**.

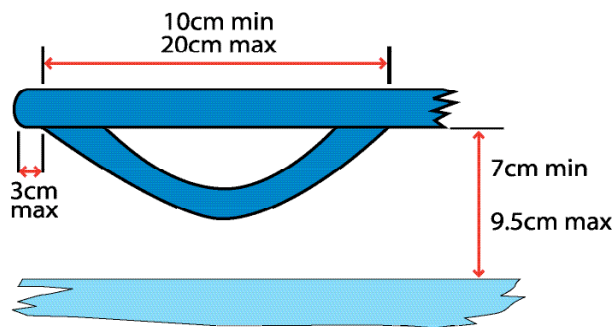

Skids **can not** be designed in the following styles:



### 303 - FOOT GUARD/ SUPPORT

A foot guard/support is required of **ALL PLAYERS**, regardless of disability, and shall be made of the same material as the main frame, and have a diameter of not less than **1.5cm minimum** and **3cm**.

- The foot guard/support shall vary in height (**depending on each player's foot size**), but shall be a minimum of **15cm** high.
- The foot guard/support must not extend outside the main frame, and must not extend above the players feet/foot.
- Note: please refer to rule 304 foot protection.

Double amputees:

- The foot guard/support for double amputees, shall be a minimum of **5cm** high.

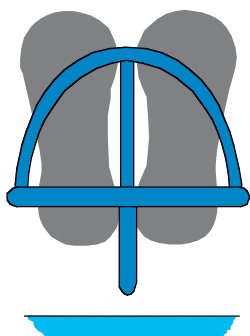

15cm minimum Single leg and Non Amputees  
5cm minimum Double Amputees

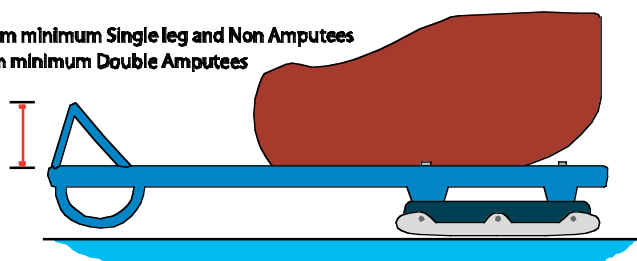

**304 - FOOT PROTECTION**

All Players, including Goalkeeper's, are required to wear **Ice Hockey Skate Boots** as protection for the foot and ankle area, **(based on their disability)**. A guard built into the main frame may also act as suitable protection as long as it covers the entire foot and ankle area.

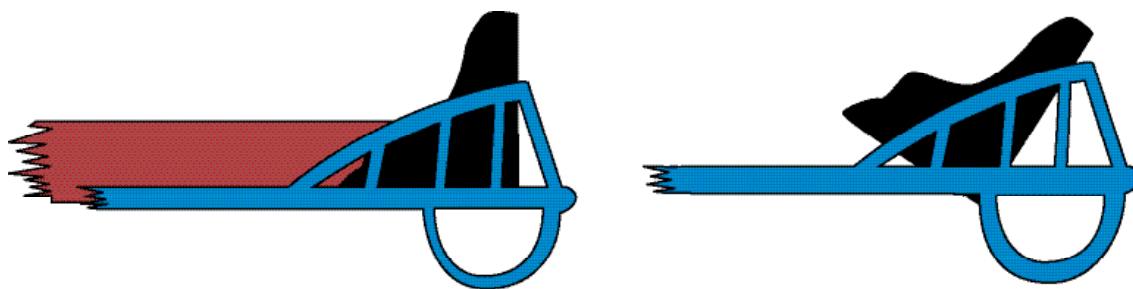
**305 - SKATE BLADES/ BLADE CARRIER**

Each Sledge shall be mounted with one (1) blade minimum and two (2) blades maximum, mounted parallel and square under the seat of the sled, there is no minimum width that the blades are set apart. The maximum width is the width of the seat. The blades must be a **minimum 16cm** and no longer than **32cm maximum**. The blades must not protrude more than one (1) centimeter beyond the front or back of the blade carrier.

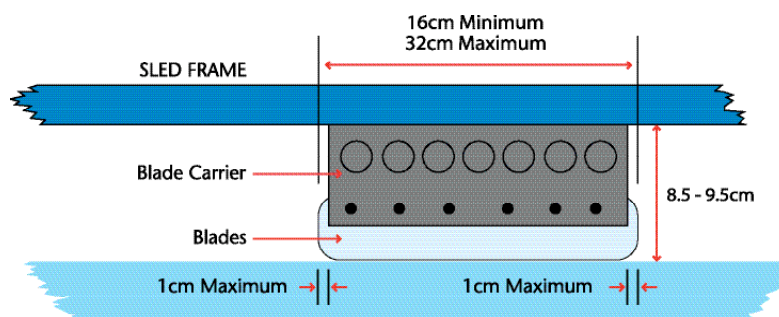
**306 - SLEDGE SEAT (BUCKET)**

a) The Seat may be made from any suitable material and must have no sharp edges **(edges rounded off)**. No more than 1cm of the frame may protrude beyond the rear of the seat.

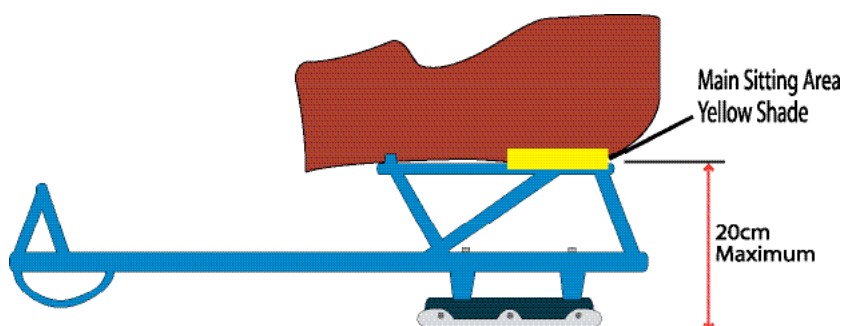

b) The maximum height a seat may sit above the ice is **20cm**, measured from a flat surface to the lowest point of the underside of the main seating area of the seat. (See diagram below.)

c) Removable seat cushions or built-in padding or combination thereof must **NOT** exceed **5cm** in height, nor overlap the seat.

- d) No external projection or protuberance beyond the seat or back support towards the rear of the sledge will be allowed in excess of **1cm**.
- e) Straps and/or adhesive tape may be used to secure players feet, ankles, knees and hips to the sledge.

### 307 - HOCKEY STICK

Sticks may be made of wood or other material, such as carbon, aluminum, fiberglass or plastic. They shall not have any projections and all edges must be beveled.

Adhesive non-fluorescent tape of any colour may be wrapped around the stick at any place.

Dimensions:

Shaft: **maximum length** – 100cm from the toe to the pick end of the shaft  
**minimum width** – 2cm.  
**minimum thickness** – 2.8cm.  
the shaft must be straight

Blade: **maximum length** – 32cm from the heel to the toe.  
**maximum width** – 7.5cm.

The players stick blade may be curved, and the curvature shall be restricted in such a way that the distance of a perpendicular line, measured from a straight line drawn from the heel to the centre end of the blade, shall not exceed 1.5cm.

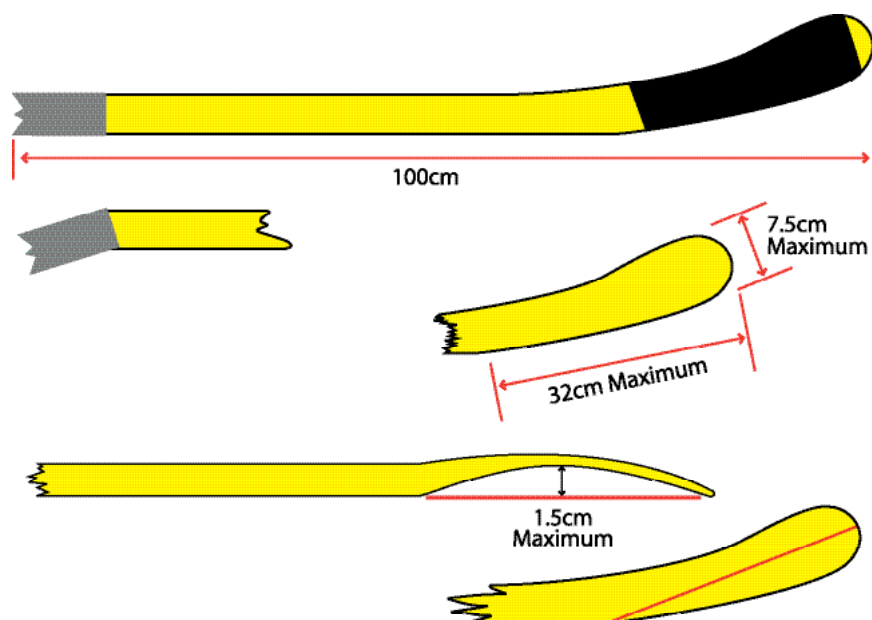

**308 - PICKS**

The depth of the **TEETH** on the “pick-ends” shall **NOT** extend more than **4mm**. A set of “pick-ends” must be fixed to the lower or butt end on each side of the stick, and have at least a total of 6 teeth of equal length per stick (**a minimum of 3 each side**). The “pick ends” may be made of any strong material, including steel, and the entire length of the “body” of the pick may not be longer than **10.2cm (4 inches)**. The “pick-ends” shall not extend more than 1cm beyond the butt end of the of the stick. The “pick-end” may be beveled but not extend beyond 1cm at any angle.

Pick:

**minimum width** – 3.2cm.

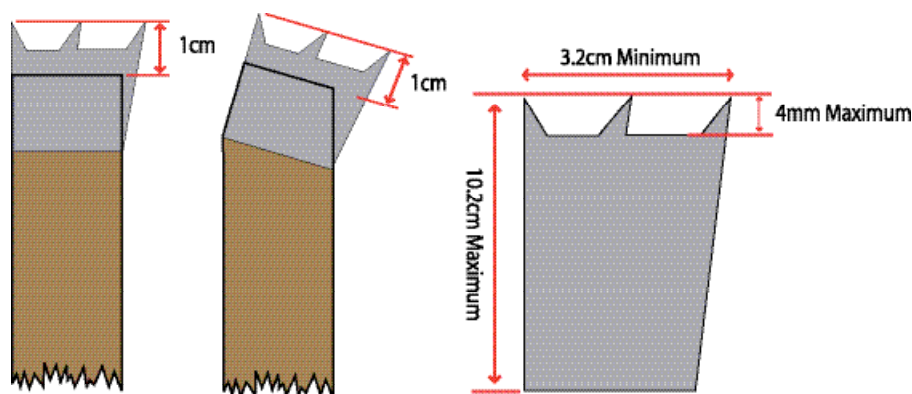
**CLOTHING****309 - UNIFORMS**

All players and Goalkeeper's from each team shall be dressed uniformly in sweaters, pants, socks and helmet (**except for the goalkeeper(s) who is permitted to wear a helmet of a different colour to the rest of the team**).

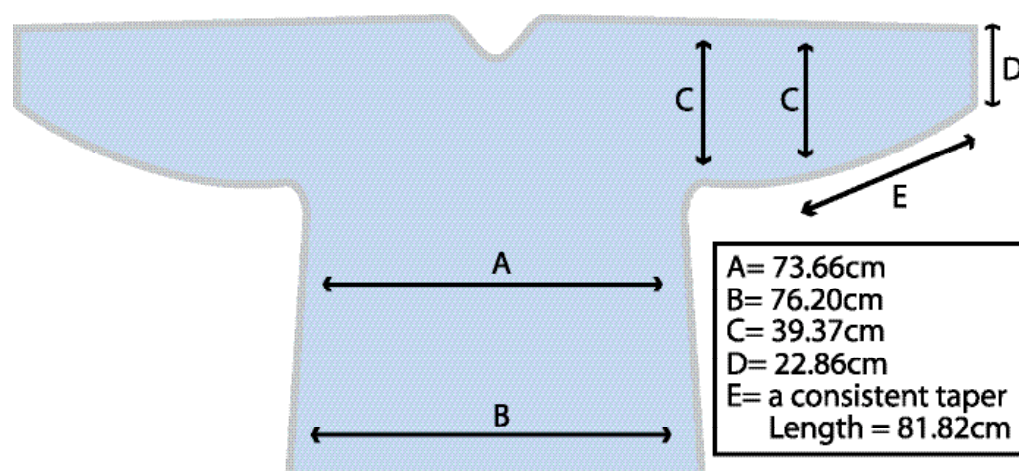

- a) The basic colour must cover approximately 80 percent of each part of the equipment, excluding names and numbers.

- b) Sweaters, including the sleeves, and socks shall be of the same colour.
- c) Sweaters shall be worn so that no part of it hangs below the sledge frame.
- d) Each player shall wear an individual number **25** to **30cm** high, centered on the back of the sweater and **10cm** high on both sleeves. Numbers are limited to the 1 to 99.
- e) The Captain must wear the letter «**C**» and Alternate Captains must wear the letter «**A**», **8cm** in height and in a contrasting colour, in a conspicuous position on the front of their sweater.

In IPC competitions, each player shall wear his name centered on the upper portion of the back of his sweater, printed **8cm** high, in block capital Roman letters.

1. Any team or player and goalkeeper that does not comply with these provisions shall not be permitted to participate in the game.
2. If, in the opinion of the Referee, the uniform color of the competing teams are so similar that there is the possibility of miscalling a penalty, it is the responsibility of the home team to change their sweaters, if ordered to do so by the Referee.
3. If a player's hair is long and obscures the nameplate or number on the sweater, the hair must be worn in a ponytail or under the helmet.

### **PROTECTIVE EQUIPMENT (ACCESSORIES AND FOOT PROTECTION)**

Protective/ Accessories shall be defined as:

helmet; full facemask; gloves; throat protector; mouth guard; shin protection; elbow pads; and shoulder pads.

#### **310 - HELMET**

During the game and during the pre-game warm-up, all players must wear a hockey helmet that is **HECC** approved with chin strap properly fastened. A helmet shall be worn so that the lower edge of the helmet is not more than one finger width above the eyebrows, and there should only be enough room between the strap and the chin to insert one finger.

#### **311 - FULL FACE MASKS**

During the game and during the pre-game warm-up, all players must wear a full face mask that is approved by **HECC**. The full face masks must be constructed in such a way that neither the puck nor a stick blade and the pick end might get through it.

**Colored or tinted full face masks and visors are not permitted.**

#### **312 - GLOVES**

During the game and during the pre-game warm-up, all players must wear gloves that cover hand and wrist, and the palm must not be removed to permit the use of bare hands. All players must wear ice hockey players gloves.

**313 - THROAT PROTECTOR**

During the game and during the pre-game warm-up, all players must wear a neck/throat protector.

Medical exemptions may be approved.

**314 - MOUTH GUARD**

During the Pre-game Warm-up and during the game, it is recommended that all players wear a custom designed mouth guard.

**315 - SHIN PROTECTION**

During the Pre-game warm-up and during the game, all players must wear shin protection covering the area between the ankles and knees as per their disability.

**316 - ELBOW PADS**

During the Pre-game warm-up and during the game, all players must wear elbow protection covering the back of the elbow joint.

**317 - SHOULDER PADS**

During the Pre-game warm-up and during game, all players must wear shoulder protection covering the shoulder area and upper arm area between the elbow and shoulder joint.

**MEASUREMENT TOOLS****318 - SLEDGE HEIGHT MEASUREMENT TOOL**

This tool may be designed of any material, with the dimension of **8.5cm** minimum and **9.5cm** maximum. It is recommended the tool be **15cm** long and **2cm** wide for stability.

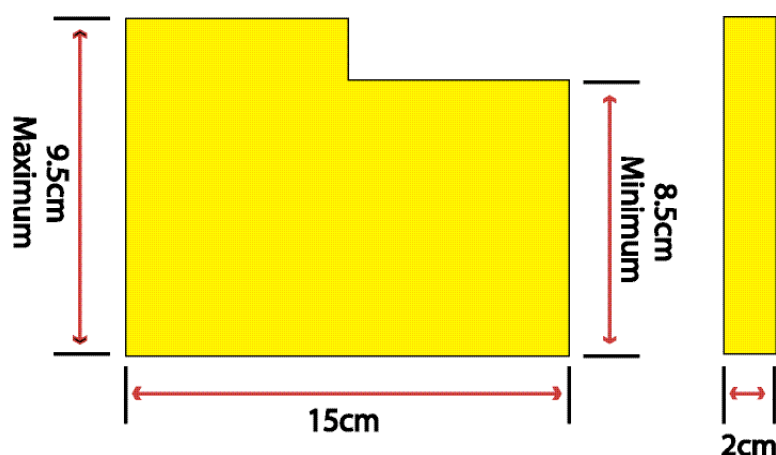

To secure a proper frame MEASUREMENT:

- Place sled on a stable flat surface.
- Apply pressure to the center of the bucket seat.
- Run/slide MEASUREMENT tool along the flat surface underneath the sled. The sled frame **can not** sit below 8.5cm and **can not** rise above 9.5cm.

### 319 - PICK MEASUREMENT TOOL

The pick MEASUREMENT tool may be designed of any material. The tool must indicate a minimum/maximum height of **1cm**, and indicate a depth of the teeth on the “pick-ends” of **4mm** minimum/maximum.

- For a proper MEASUREMENT place tool between the teeth at the butt end of the stick.

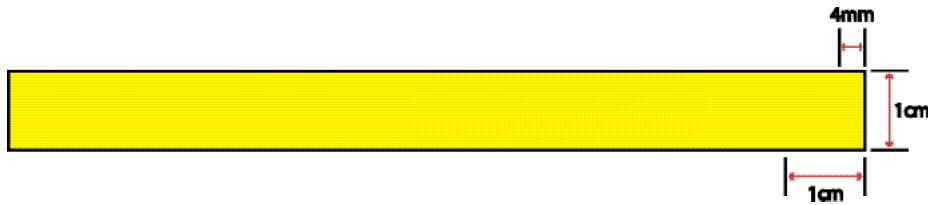

### 320 - SLED LENGTH MEASUREMENT STANDARD

Sled MEASUREMENT will be made in the following manor:

- The sled will be placed with the bucket seat/frame touching a solid flat surface.
- A solid block designed of any material, will be placed, touching the outside edge of the front of the frame.
- A standard measuring tape shall be drawn along the ground from the bucket/frame to the front edge of the frame, as indicated in the diagram.

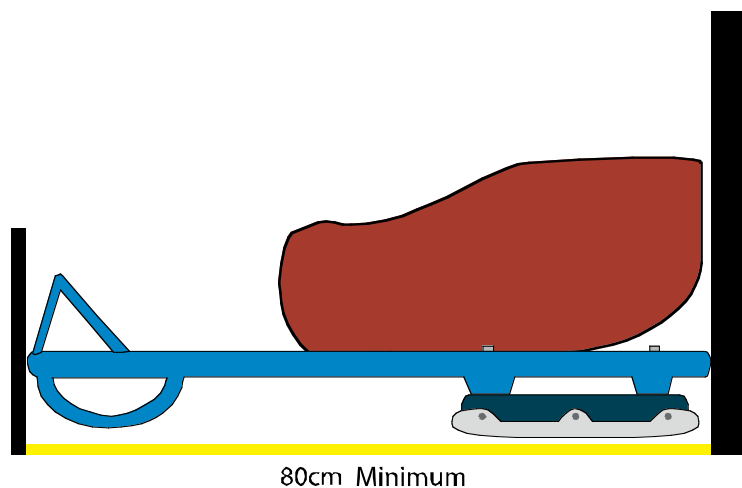

## SECTION 4 - GOALKEEPER EQUIPMENT (MOBILITY DEVICES), PROTECTIVE CLOTHING, ACCESSORIES AND FOOT PROTECTION

### Note:

The IPC Ice Sledge Hockey Sport Technical Committee may conduct equipment verification to ensure equipment adheres to the rules. The IPC ISH STC reserves the right to conduct equipment verification at anytime throughout the competition including, but not limited to pre-competition training.

### 400 - GOALKEEPER SLEDGE FRAME

a) Sledge frames may be constructed of the following approved material: Steel, aluminum, titanium. The Material must be cylindrical and not have a diameter smaller than **1.5cm** or greater than **3cm**.

b1) The frames main side rails shall be **15cm MINIMUM** width (measured from the out side of the frame) and a maximum width no greater than the seat of the sled. The side rails of the frame may taper underneath the seat to accommodate the blades; any taper must **NOT** exceed **45 degrees**.

No more than **1cm** of the frame may protrude beyond the rear of the seat or in the event the player sits cross legged, beyond the legs.

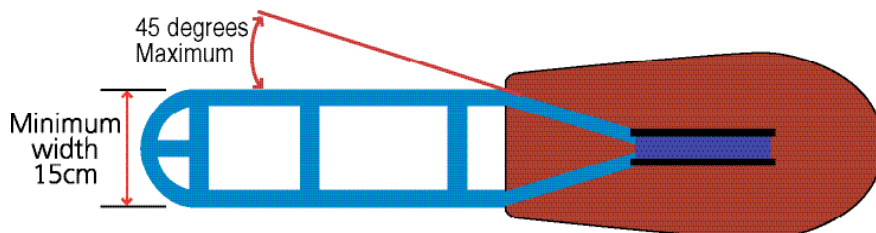

b2) In the case of a double amputee player, the blade/ blade carrier may sit on the rear end of the frame. The frame must protrude **1cm** beyond the end of the blade.

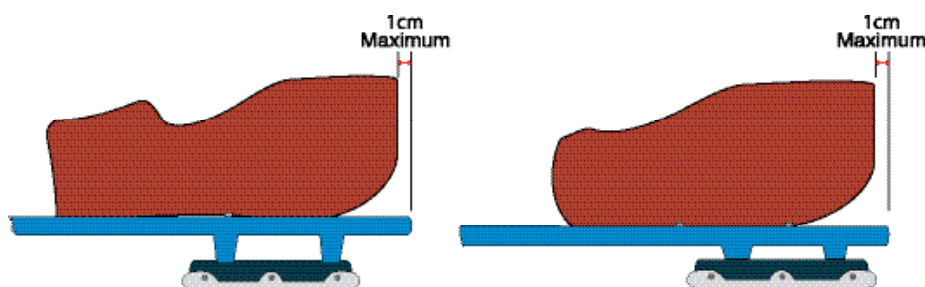

- c) The front of the sledge shall have a continuous curve with a maximum radius **one half (1/2)** of the inside width of the frame at its widest point forward of the seat.

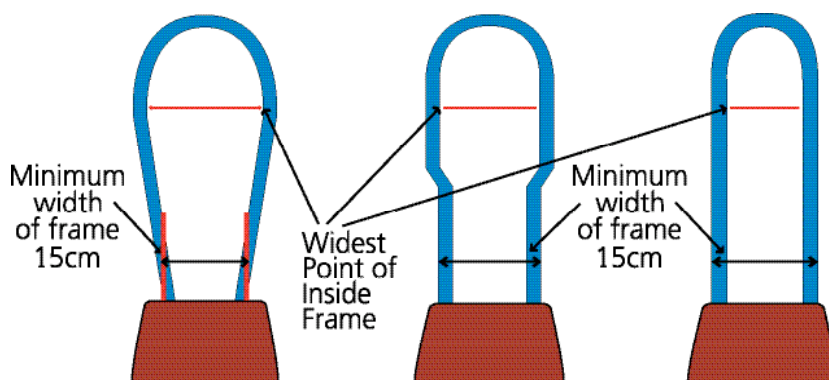

- d) The frame may be fitted with a maximum of **(4)** four cross members, and one foot rail, mounted forward of the seat. The cross members may be square or cylindrical and not have a diameter smaller than **1.5cm** or greater than **3cm**.

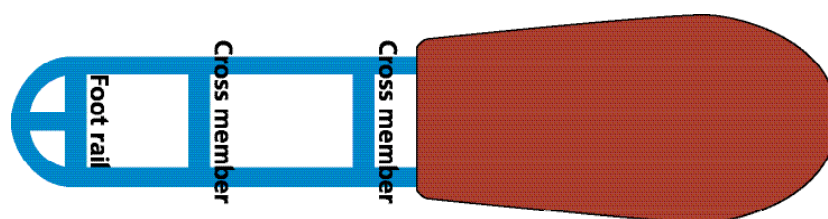

- e) The height of the main frame measured from the ice to the bottom of the frame shall be **8.5cm minimum - 9.5cm maximum**.

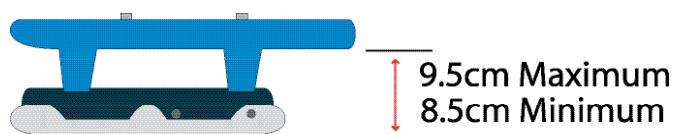

- f) Players seats/buckets may sit on the ice hockey blades/ blade carrier, as long as it is not below **5cm**.

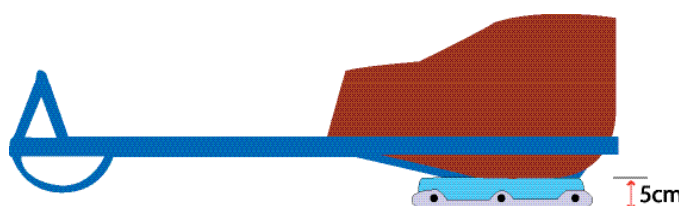

- g) The minimum length of the goalkeepers' sled frame must:
- 1 Extend **10cm** beyond the front end of the players seat bucket.
  - 2 Accommodate the required **minimum 10cm** length of the front skid.
  - 3 Shall have a foot guard/support not be less that **5cm high minimum** and no more that **15cm high maximum**. If applicable.

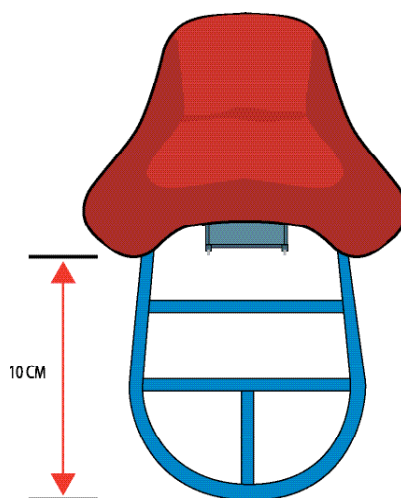

#### 401 - HEEL SUPPORT

Each Sledge may have a heel support with a maximum width of **10cm**. If the player is a single amputee, a second support may be used for the stump (**maximum width of 10cm**). No part of the stump may hang below the frame.

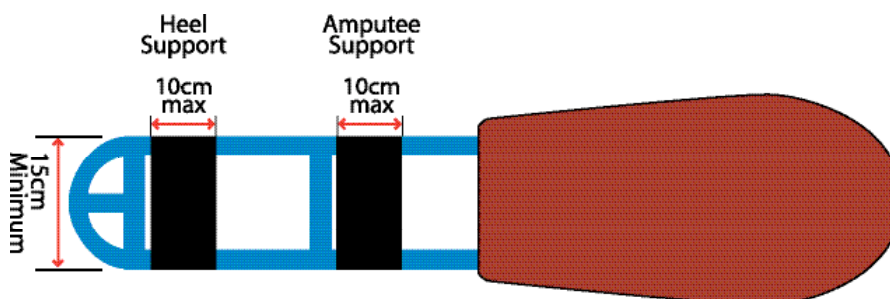

#### 402 - FRONT SKID

The Sledge must have one skid. The front skid must be attached to the frame not more than 3cm from the front of the main frame. The skid must be mounted in the Centre of the frame and extend backwards **10cm minimum** and **20cm maximum**. The skid measured from the frame downward towards the ice must be no less than **7cm minimum** and **9.5cm maximum**.

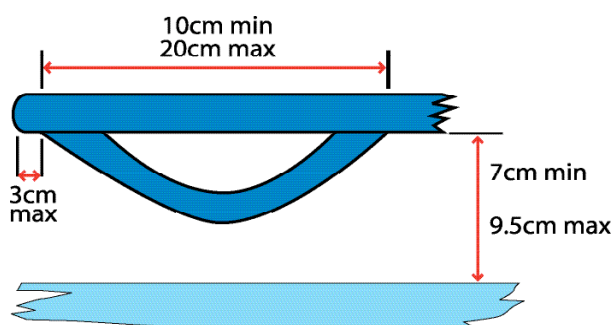

- The skid may be made of the same material as the main frame. If made of the same material, it must be cylindrical and have a diameter of not less than **1.5cm minimum** and **3cm maximum**.
- The skid may be designed of a nylon/plastic material. It may be solid in shape and have a width of not less than **1.5cm minimum** and **3cm maximum**.

Skids **can not** be designed in the following styles:

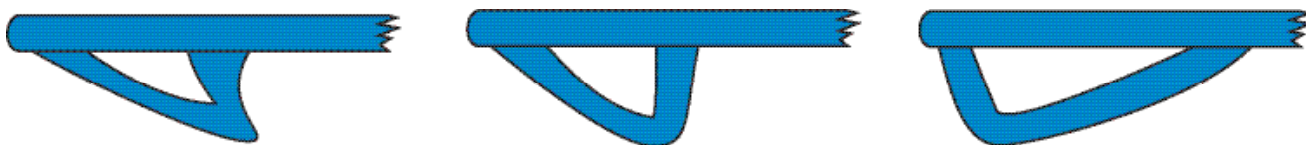

#### **403 - FOOT GUARD/ SUPPORT**

A foot guard/support shall be made of the same material as the mainframe, and have a diameter of not less than **1.5cm minimum** and **3cm maximum**.

The foot guard/support shall vary in height (**depending on each players' foot size**) and must not extend outside the main frame, and must not extend above the players feet/foot.

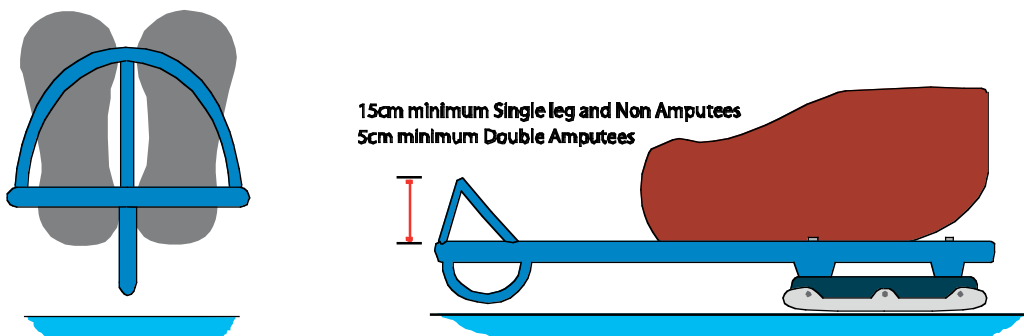

#### **404 - FOOT PROTECTION**

All Players, including Goalkeeper's, are required to wear **Ice Hockey Skate Boots** as protection for the foot and ankle area, (**based on their disability**). A guard built into the main frame may also act as suitable protection as long as it covers the entire foot and ankle area.

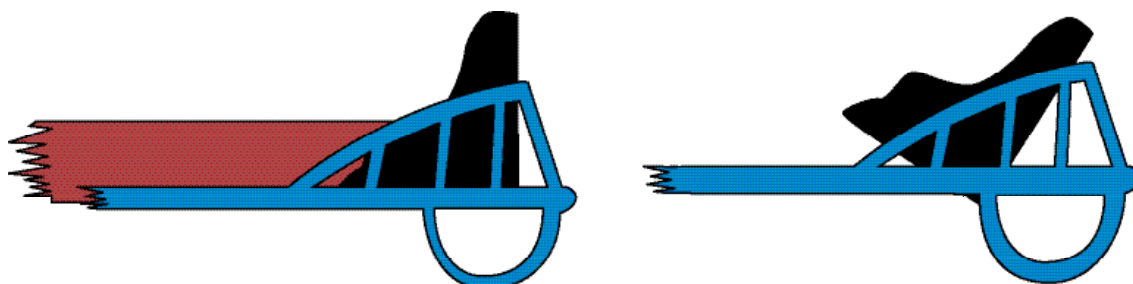

**405 - SKATE BLADES/ BLADE CARRIER**

- a) Each Sledge shall be mounted with one **(1)** blade minimum and two **(2)** blades maximum, mounted parallel and square under the seat of the sled, there is no minimum width that the blades are set apart. The maximum width is the width of the seat. The blades must be a **minimum 16cm** and no longer than **32cm maximum**. The blades must not protrude more than one **(1)** centimeter beyond the front or back of the blade carrier.
- b) Plastic blades are acceptable for Goalkeeper's only.

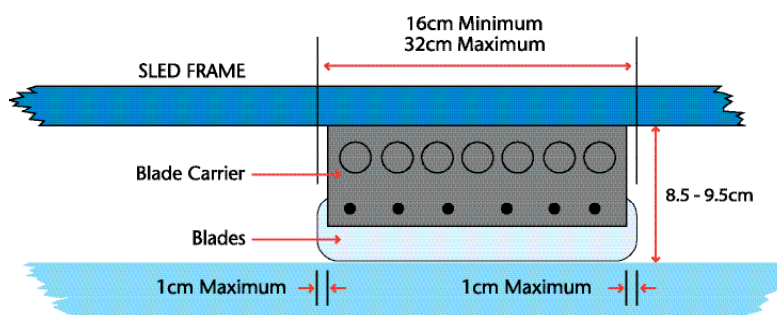
**406 - GOALKEEPER SEAT**

- a) The Seat may be made from any suitable material and must have no sharp edges (**edges rounded off**). No more than 1cm of the frame may protrude beyond the rear of the seat. If the goalkeeper sits cross-legged, the seat may be extended sideways to protect the knees, but may not protrude more than **1cm** beyond the players knees.
- b) The maximum height a seat may sit above the ice is **20cm**, measured from a flat surface to the lowest point of the underside of the main seating area of the seat. (**See diagram below.**)
- c) Removable seat cushions or built-in padding or combination thereof must **NOT** exceed **5cm** in height, nor overlap the seat.
- d) No external projection or protruding beyond the seat or back support towards the rear of the sledge will be allowed in excess of **1cm**.
- e) Straps and/or adhesive tape may be used to secure players feet, ankles, knees and hips to the sledge.

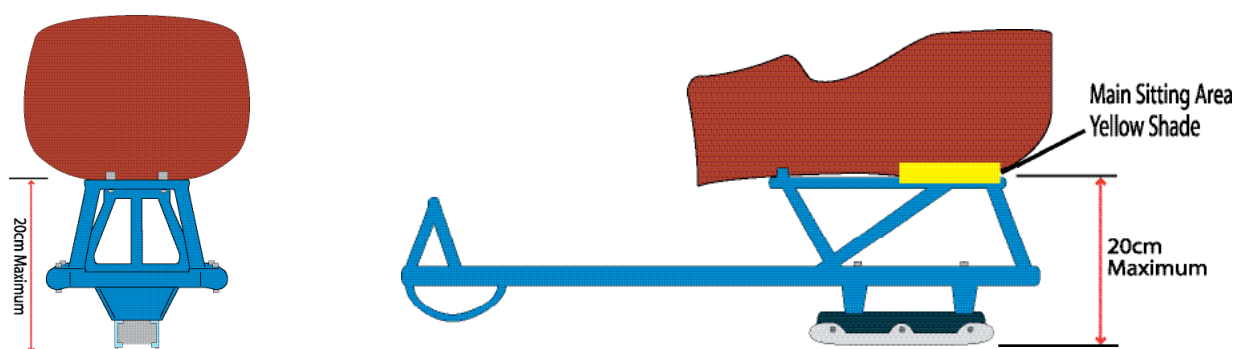

**407 - GOALKEEPER'S STICKS**

Sticks shall be made of wood or other material, such as aluminum, fiberglass or plastic. It must not have any projections and all edges must be beveled. Adhesive non-fluorescent tape of any colour may be wrapped around the stick at any place.

Dimensions:

	<b>-maximum length</b>	– 100cm measured along the centre line.
Shaft:	<b>-must have a minimum width of</b>	– 2cm
	<b>-minimum thickness</b>	– 2.8cm
	<b>-minimum length</b>	– 30cm
Blade:	<b>-maximum length</b>	– 38cm from the heel to the toe.
	<b>-maximum width</b>	– 9cm

The Goalkeeper's stick blade may be curved, and the curvature shall be restricted in such a way that the distance of a perpendicular line, measured from a straight line drawn from any point at the heel to the end of the blade, shall not exceed 1.5cm. The Goalkeeper's stick may have an additional pick at the base of the blade not exceeding 1cm, set at 90 degrees at the butt end of the stick to facilitate movement back and forth in the goal (i.e. push or pull).

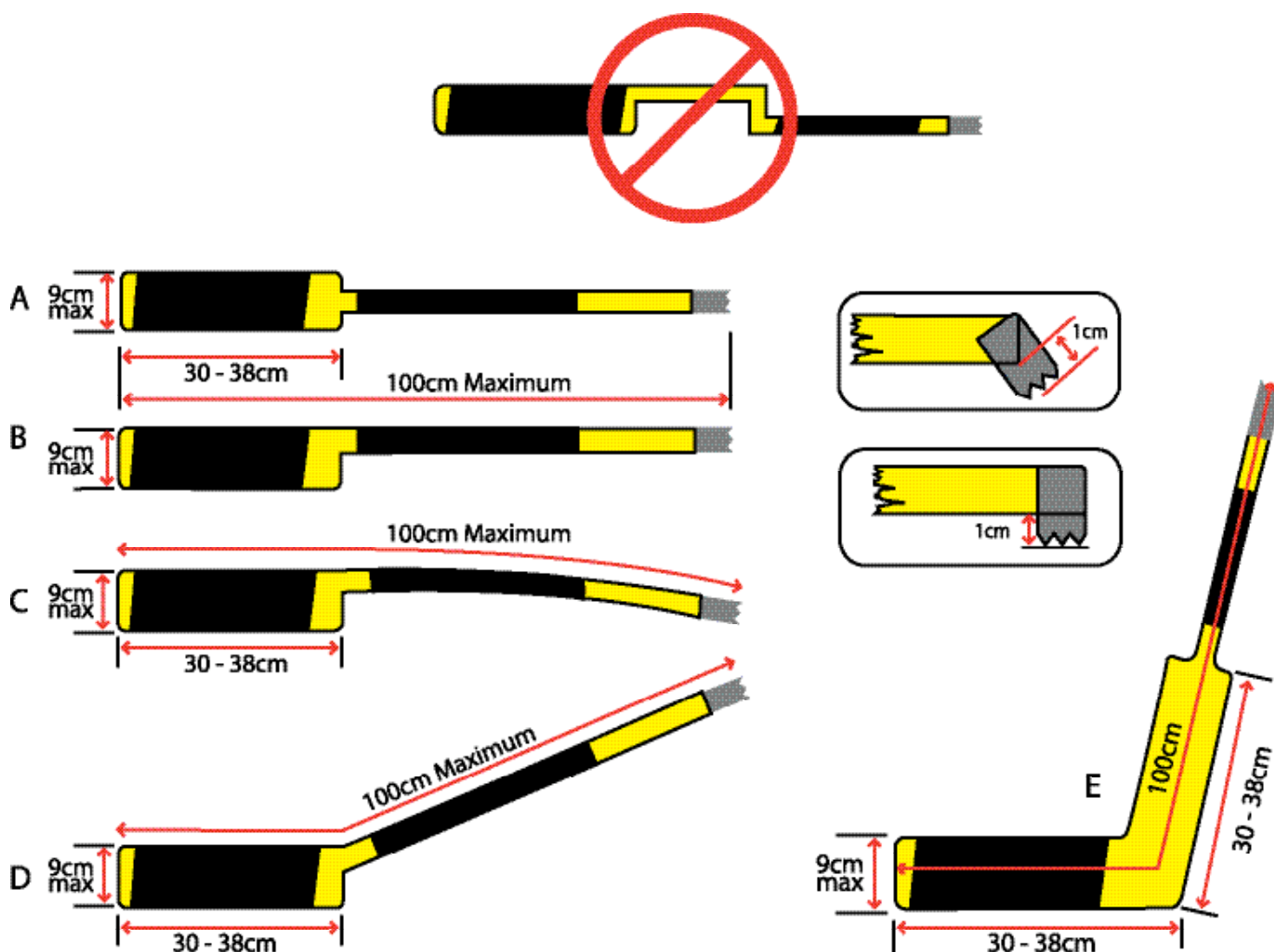

**408 - GOALKEEPER'S GLOVES**

The maximum outside dimensions of the catching glove shall not exceed: **20.32cm** in length at any part of the wrist cuff, which shall be **10.16cm** in width (height). Distance from the heel along the pocket to the top of the T trap shall be no more than **46cm**. The perimeter of the catching glove shall not exceed **114.3cm**.

These shall be allowed to have fixed protuberances or picks protruding but must be securely attached to the catching glove. The picks shall not exceed **1cm** in length.

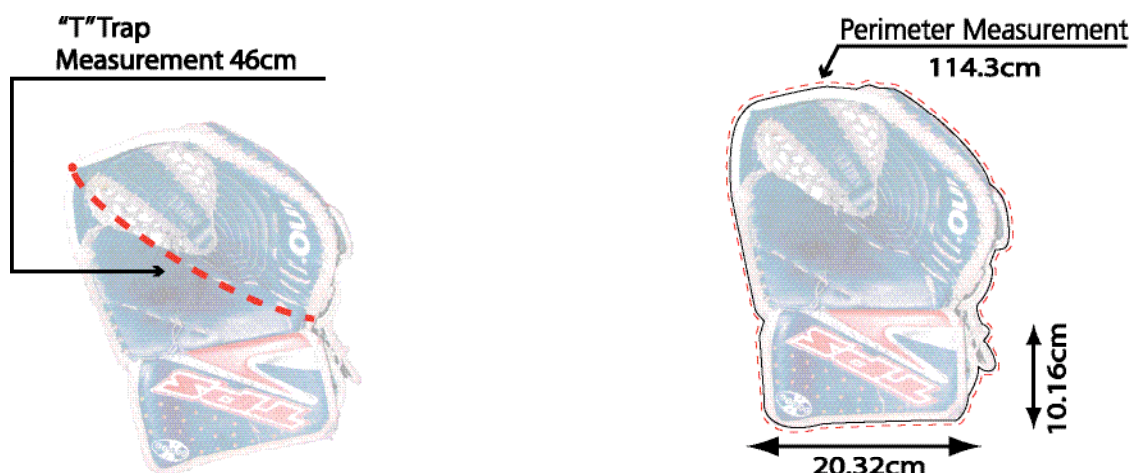
**409 - BLOCKING GLOVE**

The maximum dimensions of the protective padding attached to the back of the forming part of a blocking glove, shall measure:

**38.1cm** in length  
**20.32cm** in width

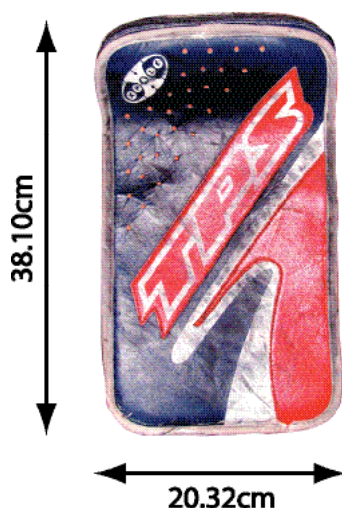
**CLOTHING****410 - GOALKEEPER CLOTHING**

Refer to clothing specifications **Rule 309**.

## **PROTECTIVE EQUIPMENT (ACCESSORIES)**

### **411 - GOALKEEPER'S HELMET AND FULL FACE MASK**

- a) During the game and during the pre-game warm-up, all Goalkeeper's must wear an ice hockey full-face mask with a hockey helmet, or a goalkeeper's full-face head protector.

Goalkeeper's face masks must be constructed in such a way that a puck may not get through it, that neither the puck, nor a stick blade, and nor the pick end might get through it.



### **412 - GOALKEEPER'S LEG GUARDS**

The goalkeeper's side leg guard shall not exceed 5cm higher than the leg(s) of the goalkeeper, and not extend beyond the feet. A goalkeeper may use hockey shin guards, or baseball shin guards as protection. These guards must be worn on the outside of the uniform. A plate or any kind of device covering the space between the sledges frame is not permitted.

## **MEASUREMENT TOOLS**

Refer to **Rule 318, 319 and 320**

## SECTION 5 - COMPETITION EQUIPMENT

### **501 - Puck**

The «PUCK» shall be made of vulcanized rubber and comply with the IPC Ice Sledge Hockey Regulations regarding logo, trademark and advertising placement and be primarily black in colour.

The dimensions of a puck shall not exceed:

- Diameter - 7.62cm
- Thickness - 2.54cm
- Weight - 156 to 170gms

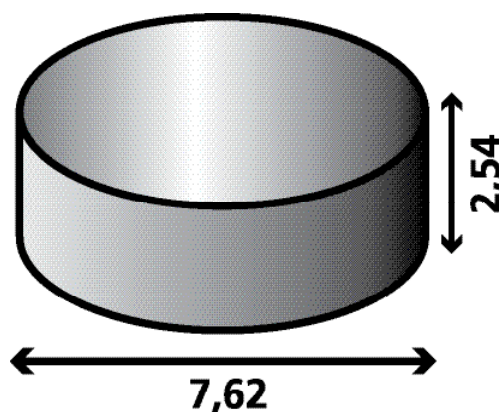



## **SECTION 6 - GAME FORMAT**

### **600 - TIMING OF GAME**

The regular game shall consist of three **(15)** minute actual time periods and two **(15)** minute intermissions. The teams shall change ends for each period.

### **601 - START OF GAME AND PERIODS**

A game or period shall begin with a face-off at the centre face-off spot. The teams shall start a game defending the goal nearest to their team bench.

Teams shall change ends for each succeeding period (**regular or overtime**). Teams shall not change ends when the ice has not been resurfaced for an overtime period or game winning penalty shots period.

1. Playing time shall commence from the instant the puck is faced-off and shall stop when the whistle is blown.
2. If any unusual delay occurs within five minutes of the end of the first and second period, the Referee may order the next regular intermission to be taken immediately. When play resumes, the remaining time shall be played with the teams defending the same goal as before the intermission, after which time the teams change ends and resume playing the ensuing period without delay.
3. During the intermissions the ice shall be resurfaced.
4. All players must leave the ice during the resurfacing and not return until ordered to do so by the Referee.
5. If the teams are unable to leave the ice surface, the referee will designate an area of the ice for each team to rest while the ice is being resurfaced.

### **602 - TIME-OUT**

- a) Each team shall be permitted one **(1)** minute time-out during the course of regular time or during overtime.
- b) During a normal stoppage of play, any player designated by the Coach may ask the Referee for the time-out. The Referee shall report the time out to the Score-keeper.
- c) The players and goalkeeper's of both teams, except for penalised players, are allowed to go to their respective team benches.
- d) Each team may take their time-out at the same stoppage of play, but the team taking the second time-out shall notify the Referee before the end of the first time-out.

**603 - DETERMINING THE OUTCOME OF THE GAME**

- a) The team scoring the greatest number of goals during the three (15) minute periods shall be declared the winner and shall be credited with two points in the standings.
- b) If, at the end of the game, the score for both teams is equal, the game shall be declared a tie with one point credited to each team.
- c) In a game where a winner must be declared, the game shall be prolonged by a ten minute actual time "Sudden Victory" overtime period (see [Rule 604](#)).
- d) If no goal is scored, "Game Winning Penalty Shots" shall apply (see [Rule 605](#)).

**604 - OVERTIME PERIOD**

If in a Preliminary Round or Qualification Round game, the game is tied at the end of regulation time, a five-minute overtime period shall be played immediately after an intermission of three minutes. The teams will defend the same goals as in the third period. The game will end when the five minutes has expired or when a goal is scored; the scoring team will be declared the winner. If no goal is scored in the overtime period then the Game Winning Shots Procedure will apply.

If a playoff game, a Quarter Final game, a Semi-Final game or a Bronze Medal game is tied at the end of regulation time, then a ten-minute overtime period shall be played immediately following the completion of an intermission of three minutes. The teams will defend the same goals as in the third period. The game will end when the ten minutes has expired or when a goal is scored; the scoring team will be declared the winner. If no goal is scored in the overtime period then the Game Winning Shots Procedure will apply.

If a Gold Medal Final Game is tied at the end of regulation time, then a fifteen-minute overtime period shall be played immediately following the completion of a 15-minute intermission during which the ice will be resurfaced. The teams will change ends for the overtime period. The puck will be faced off at center ice. The game will end when the fifteen minutes has expired or when a goal is scored; the scoring team will be declared the winner. If no goal is scored in the overtime period then the Game Winning Shots Procedure will apply.

All overtime periods of any IPC game shall be played with each team at the numerical strength of four (4) skaters and one (1) goalkeeper. Specific rules for this procedure are as follows:

1. If a team is penalized in overtime, the teams will play 4-on-3. Coincidental penalties do not affect the on-ice strength when assessed in overtime.
2. In overtime, if a team is penalized such that a two-man advantage is called for, then the offending team will remain at three (3) skaters while the non-offending team will be permitted a fifth skater.
3. At the first stoppage of play after the two-man advantage is no longer in effect, the

numerical strength of the team will revert back to either a 4-on-4 or a 4-on-3 situation, as appropriate.

4. If there is a manpower advantage situation, which carries over from regulation time to overtime, the above criteria will be applied at the start of the overtime. Accordingly, if at the end of the regulation time, the teams are 5-on-4, overtime begins at 4-on-3.
5. When the regulation time ends with on-ice manpower strength of 5-on-3, teams will commence the overtime with a strength of 5-on-3. With the expiration of penalties, due to continuous action, player strength may get to 5-on-5 or 5-on-4. At the first stoppage of play following, player strength must be adjusted to 4-on-4 or 4-on-3.
6. If at the end of regulation time teams are 3-on-3, overtime starts 3-on-3. Once player strength reaches 5-on-4 or 5-on-5, at the next stoppage player strength is adjusted to 4-on-3 or 4-on-4, as appropriate.
7. If at the end of regulation time teams are 4-on-4 with a player or players in the box serving non-coincidental penalties, overtime starts 4-on-4 and players exit the penalty box as normal to 5-on-4 or 5-on-5. At the first stoppage of play, teams are adjusted to 4-on-3 or 4-on-4, as appropriate.

#### **605 - GAME WINNING PENALTY SHOTS**

If no goal is scored in the overtime period then the IPC Game Winning Shots Procedure will apply. The following procedure will be utilized:

1. The Teams will not change ends for the **"Game Winning Shot"** procedure. The center section of the rink will be dry scraped by the ice-resurfacing machine prior to the **"Game Winning Shots"** during the time required to organize the program accordingly. The Home team shall have the choice of shooting first or second.
2. The procedure will begin with three different shooters from each team taking alternate shots. The players do not need to be named beforehand. Eligible to participate in the **"Game Winning Shots"** will be all players from both teams listed on the official game sheet except as specified in article 3 below.
3. All players are eligible to participate in the **"Game Winning Shot"** procedure unless they are serving a Misconduct penalty or have been assessed a Game Misconduct or Match Penalty.
4. Once the **"Game Winning Shot"** procedure begins, the goalkeeper cannot be replaced unless he/she is injured. No warm up shall be permitted for a substitute goalie.
5. The shots will be taken in accordance with the IPC Official Rule Book.

6. The players of both teams will take the shots alternately until a decisive goal is scored. The remaining shots will not be taken.
7. If the result is still tied after 3 shots by each team the procedure shall continue with a **"Tiebreaker Shoot-Out"** by one **NEW** player of each team, with the other team starting to take the tiebreak shots the game shall be finished as soon as a duel of two players brings the decisive result.
8. The Official Score-keeper will record all shots taken, indicating the players, goalkeeper's and goals scored.
9. Only the decisive goal will count in the result of the game. It shall be credited to the player who scored and to the goalkeeper concerned.
10. If a team declines to participate in the **"Game Winning Shots"** procedure the game will be declared as a loss for that team and the other team will be awarded 3 points for a win. If a player declines to take a shot it will be declared **"no score"** for his team.
11. The number of eligible players for the tiebreak shots will be determined by the team with the fewest number of eligible players in uniform and on the bench at the conclusion of regulation time.

## SECTION 7 - TEAMS

### 700 – TEAM COMPOSITION AND PLAYERS IN UNIFORM

For a game, each team may comprise a maximum of **(13) players**, and **(2) Goalkeeper's**, for a total of **(15)** eligible athletes wearing the designated team uniform. The names, number assignments and other required information for officiating the competition must be provided by each team prior to a game in accordance with the IPC Ice Sledge Hockey Regulations. No changes or additions shall be permitted to the list once the game has started.

### 701 – TEAM CAPTAIN

Each team must appoint a Captain and no more than two **(2) Alternate Captains** from the **(13)** players. The Captain shall have the privilege to discuss with the Referee on only matters relating to the interpretation of the rules that may arise during the course of the game. A complaint on a given penalty is not considered a matter relating to the interpretation of the rules. If a Captain or Alternate Captain is not on the ice, they cannot come off the team bench unless invited by the Referee. If both the Captain and Alternate Captain are on the ice, only the Captain has the privilege of conversing with the Referee. Players that do not wear a **"C"** or **"A"** on their jersey will not be granted the privileges of conversing with the Referee.

### 702 - ATHLETES ON THE ICE

A team shall not have more than six athletes on the ice at any time while play is in progress. Each team shall be allowed to have a maximum of one goalkeeper on the ice while play is in progress. A goalkeeper may be substituted by a player. In such case, any player on the ice shall not be permitted the privileges of the goalkeeper. The six athlete positions are:



### 703 - SUBSTITUTION OF PLAYERS AND GOALKEEPER'S

- a) Players and Goalkeeper's may be substituted at any time during play or stoppage time.
- b) If, during a substitution, either the player/goalkeeper entering the ice or the player/goalkeeper leaving the ice plays the puck or intentionally makes physical contact with an opposing player/goalkeeper while the retiring player/goalkeeper is actually on the ice, the Referee shall assess a:
  - ➔ **Bench Minor penalty (see Rule 1062)**
- c) If, during the substitution, the puck strikes either the entering player/goalkeeper or retiring player/goalkeeper accidentally, the play will not be stopped and no penalty shall be assessed.
  1. No warm-up shall be allowed to any player or goalkeeper at the end of the first and second period, or during any stoppage of play.
  2. In the application of the rule, the change of one or more players shall constitute a line change.

**704 - CHANGE OF PLAYERS AND GOALKEEPER'S FROM THE TEAM BENCH DURING PLAY**

- a) The players and Goalkeeper's may be changed at any time from the team bench while the game is in progress provided that:
- The changing of players and Goalkeeper's within an area limited by the length of the respective team bench and 3m from the boards, as illustrated on the opposite page.
  - The changing players and Goalkeeper's are out of the play before any change is made.

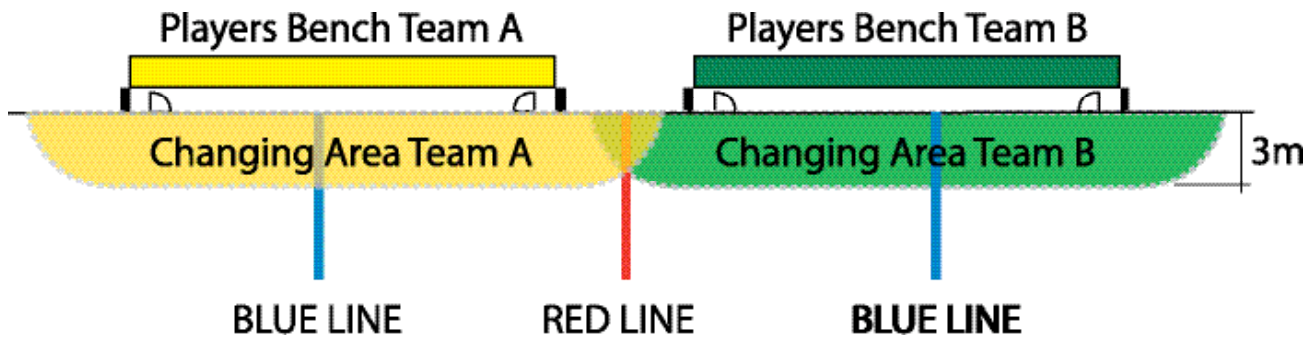

- b) If, when a goalkeeper leaves his goal crease and proceeds to his team bench for the purpose of substituting another player and if the substitution is made prematurely, the official shall stop the play when the offending team gains possession of the puck. The ensuing face-off shall take place at the centre ice face-off spot, except in the cases where the offending team would gain a territorial advantage, in which case the face-off (see **Rule 900 G**) shall be where the stoppage of play occurred.

**705 - CHANGE OF PLAYERS PROCEDURE DURING STOPPAGE OF PLAY**

- a) Following a stoppage of play, the visiting team shall promptly place a line-up of players on the ice for play and no substitution shall be made until play has resumed. The home team may then make any desired substitution which does not result in the delay of the game.

If there is any undue delay by either team in changing lines, the Referee shall order the offending team or teams to take their positions immediately and shall not permit a line change

- b) The procedure shall be carried out as follows:
1. The Referee shall take his position for the start of the next play, and the Linesman dropping the puck shall proceed promptly to the location of the face-off.
  2. The Referee shall allow the visiting team ten seconds to make their player changes.
  3. After the ten seconds, the Referee shall raise his arm to indicate that the visiting team shall no longer make a player change.
  4. With the arm still up, the Referee shall allow the home team ten seconds to make their player changes.
  5. After the ten seconds, the Referee shall drop his arm to indicate that the home team shall no longer make a player change.
  6. As soon as the Referee drops his arm, the Linesman conducting the face-off shall blow

the whistle, which signals both teams that they shall have no more than five seconds to line-up for the face-off.

7. At the end of the five seconds, or sooner if the facing-off players are ready, the Linesman shall drop the puck. It shall not be the responsibility of the Linesman to wait for the players to come into position for the face-off.

- c) Teams are not permitted to make a player(s) substitution following a false face-off, except when a penalty is assessed that affects the on-ice strength of either team.

#### **706 - CHANGE OF PLAYERS FROM THE PENALTY BENCH**

A player serving a penalty, who is to be changed after the penalty has been served, shall proceed at once, by way of the ice, and be at his own team bench before any change can be made.

**Bench Minor penalty (see Rule 1053)**

#### **707 - CHANGE OF GOALKEEPER'S DURING STOPPAGE OF PLAY**

- a) During a stoppage of play, Goalkeeper's shall not be permitted to go to the team bench except to be replaced or during a time out.

**Minor penalty (see Rule 1065)**

- b) When a goalkeeper substitution has been made during a stoppage of play, the goalkeeper who left the game may re-enter the game as soon as the play resumes.

No warm-up shall be permitted for a substitute goalkeeper.



## SECTION 8 - SAFETY

### **801 - INJURED PLAYERS**

- a) If a player is injured and cannot continue to play or go to the team bench, the play will continue until his team has secured possession of the puck, unless either team is in an immediate scoring position.
- b) If a player other than the goalkeeper is injured or compelled to leave the ice during the game, the player/goalkeeper may retire and be replaced by a substitute, but play shall continue without the teams leaving the ice.
- c) If a penalized player has been injured he/she may proceed to the dressing room, and if he/she has been assessed a Minor, Major or Match penalty, the penalized team shall immediately put a substitute player on the penalty bench who shall serve the penalty without change, except by the injured penalized player if the player/goalkeeper is able to return.
- d) The injured penalized player shall not be eligible to play until his penalty has expired.
- e) If an injured player returns to play before his penalty has expired, the Referee shall assess additionally to this player a:

#### **Minor penalty (2')**

- If it is obvious that a player has sustained a serious injury, the Referee and/or the Linesman shall stop the play immediately.
- When play has been stopped due to an injured player, excluding the goalkeeper, the injured player shall leave the ice and may not return to the ice until after play has resumed.

#### **Minor penalty (2') (see Rule 1038 A) Important Reference**

### **802 - INJURED GOALKEEPER'S**

- a) If a goalkeeper sustains an injury or becomes ill, he/she shall be ready to resume play immediately or be replaced by a substitute goalkeeper.
- b) If both Goalkeeper's of the team are incapacitated and unable to play, the team shall have **(10)** ten minutes to dress another player in uniform as a goalkeeper.
  - In this case, neither of the two regular Goalkeeper's may return to the game.
  - No warm-up shall be permitted for a substitute goalkeeper.

### **803 - PREVENTION OF INFECTIONS**

- a) A player bleeding or covered by the blood of an opposing player will be considered as an injured player and must leave the ice for treatment and/or clean up.

- b) Such player shall be permitted to return to the ice surface provided that:
- The cut is completely closed and sealed with appropriate bandages.
  - Any blood is removed from the player and his equipment and uniform replaced or properly cleaned.

If the ice surface, ice rink facilities or any objects are stained with blood, the Referee shall ensure that the bloodstains are removed by the rink personnel after the first stoppage of play.

**804 - ICE CLEANING**

- a) The Referee has the authority to remove a build up of snow around the goal post or on the goal line near the net.

## SECTION 9 - PLAYING RULES

### 900 - FACE-OFFS

#### 901 - FACE-OFF SPOTS AND IMAGINARY LINE

##### FACE-OFF SPOTS AND IMAGINARY LINES

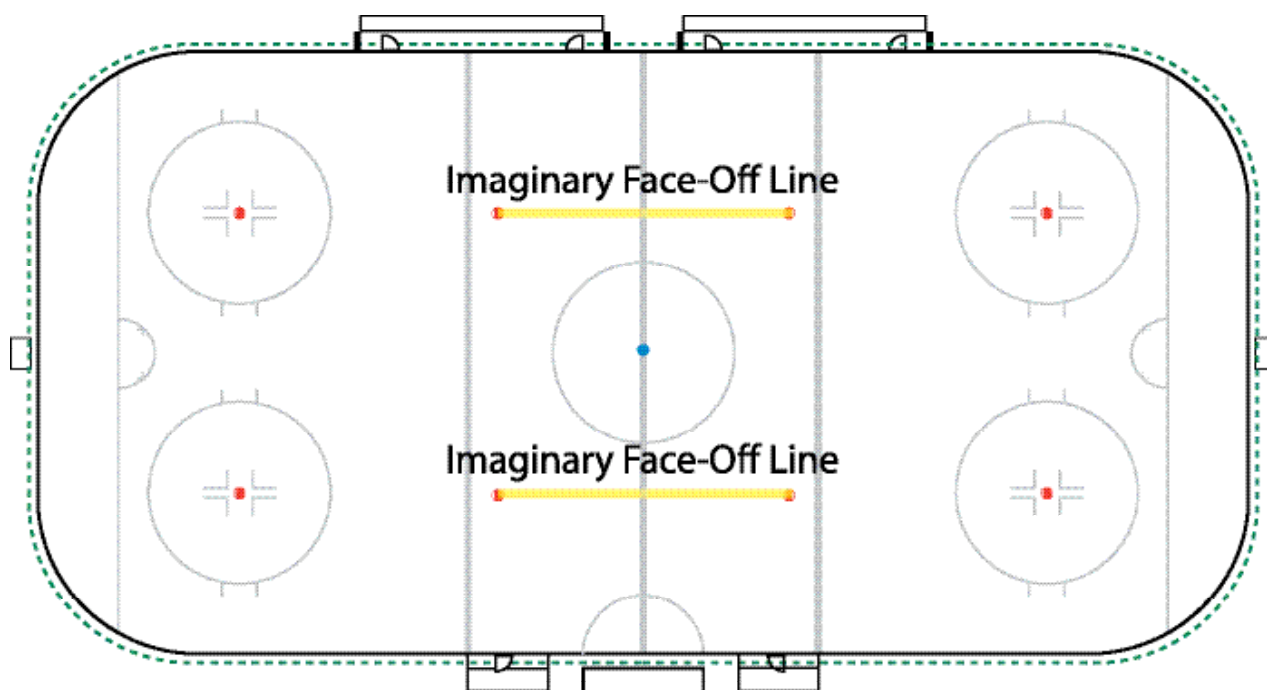

- a) A face-off shall be conducted at the beginning of each period and after any stoppage of play.
- b) All face-offs shall be conducted exclusively:
  - At the nine designated face-offs spots, or
  - On two imaginary lines parallel to the side boards and extending from one neutral zone face-off spot to the other neutral zone face-off spot.
- c) The face-offs shall be conducted at the centre ice spot:
  - At the start of a period,
  - After a goal scored,
  - After an error by an official on icing,
  - Premature substitution of a goalkeeper unless otherwise expressly provided by these rules.
- d) Face-offs shall be conducted at the end zone spots of the defending team:
  - After any infringement of the rules made by the defending team in his defending zone the puck shall be faced-off at the end zone face-off spot on the side where the stop page occurred.
  - A goal illegally scored as a result of a puck deflected off an official.
  - After an attacking team does not score on a Penalty Shot.

- e) Face-offs shall be conducted at the end zone spots of the attacking team:
  - When the puck is iced by the attacking team,
  - After an intentional offside by the attacking team.
  
- f) Face-offs shall be conducted at the neutral zone spots:
  - After an offside,
  - After any infringement of a rule made by the attacking team in his attacking zone,
  - Following a stoppage of play, should one or both defensemen who are playing near their attacking blue line or any player coming from the team bench of the attacking team enters into the attacking zone beyond the outer edge of the end zone face-off circles.
  
- g) Face-offs shall be conducted at the imaginary lines:  
After any infringement of the rules by either team at the nearest point of the line where play was stopped, unless otherwise expressly provided here above.

### **902 - PROCEDURE FOR CONDUCTING FACE-OFFS**

- a) The Referee or the Linesman will drop the puck between the sticks of the two players facing-off.
  
- b) The players shall be positioned squarely facing the sideboards of the rink, with their sleds outside of the face-off spot, and with the blade of their stick on the ice on the white part of the face-off spot.
  
- c) The player of the attacking team in his attacking half of the rink shall place his/her stick on the ice first followed immediately by the player of the defending team.
  
- d) However, when the face-off is at the centre ice spot the player of the visiting team shall place his stick on the ice first.
  - 1. The whistle shall not be blown by the official to start play.
  - 2. No substitution of players shall be permitted until the face-off has been conducted and play has resumed, except when a penalty is assessed that shall affect the on ice strength of either team.
  - 3. If the player facing-off fails to take his proper position immediately when directed to do so by the official, the official may order him replaced for the face-off by another team-mate on the ice.
  - 4. If a player enters the face-off circle, the Referee or Linesman shall blow the whistle to re-face-off the puck, unless the non-offending team gains possession of the puck.
  - 5. The Referee shall assess the corresponding penalty(s) to the offense made by the player. (see **Rule 1043 paragraph b.)**

**903 - OFFSIDES**

- a) Players of an attacking team shall not precede the puck into their attacking zone.
- b) The determining factors in deciding an offside are:
1. The player's blades position
    - player is offside when both blades are completely over the blue line in his attacking zone before the puck completely crosses the line,
  2. The puck position
    - the puck must have completely crossed the blue line into the attacking zone.
- c) In violation of this rule, play shall be stopped and a face-off shall be conducted:
1. At the nearest neutral zone face-off spot if the puck was carried over the blue line by the attacking player,
  2. At the place where the pass or shot originated when the puck was passed or shot over the blue line by an attacking player, **(see point 4 in this rule)**
  3. At the end face-off spot in the defending zone of the offending team if, in the opinion of the Linesman or Referee, a player has intentionally caused an offside.
  4. At the end zone face-off spot in the defending zone of the offending team, if the puck was passed or shot by the attacking player from his defending zone.
- d. A player actually propelling and in control of the puck, who crosses the line ahead of the puck, shall not be considered offside.
1. If a defending player carries or passes the puck into his defending zone while a player of the attacking team is in an offside position, no offside shall be called.
  2. An intentional offside is made for the purpose of securing a stoppage of play, regardless of the reason.

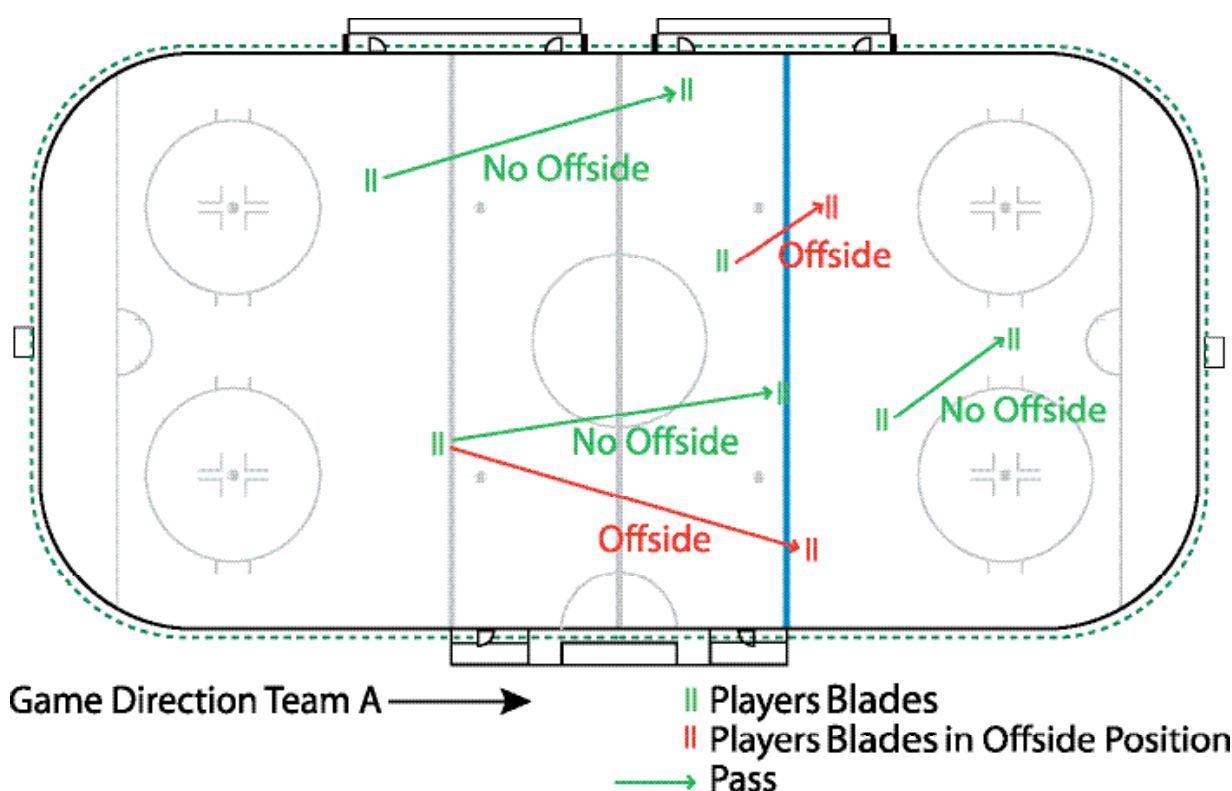

**904 - DELAYED OFFSIDE PROCEDURE**

- a) An attacking player precedes the puck into the attacking zone, but a defending player is able to play the puck, the Linesman shall raise his arm to signal a **"Delayed Offside"**, except if the puck has been shot on goal causing the goalkeeper to play the puck.
- b) The Linesman shall drop his arm to nullify the offside violation and allow the play to continue if:
  1. The defending team either passes or carries the puck into the neutral zone,
  2. Or, all attacking players immediately clear the attacking zone by making blade contact with the blue line.
- c. The attacking zone shall be completely clear of attacking players before the delayed offside can be nullified with the puck still in the attacking zone.
- d. **"Immediately"** means that the attacking players must not touch the puck, or attempt to gain possession of a loose puck, or force the defending puck carrier further back in the zone.
- e. In this second case, when the Linesman drops his arm, any attacking player may re-enter his attacking zone.

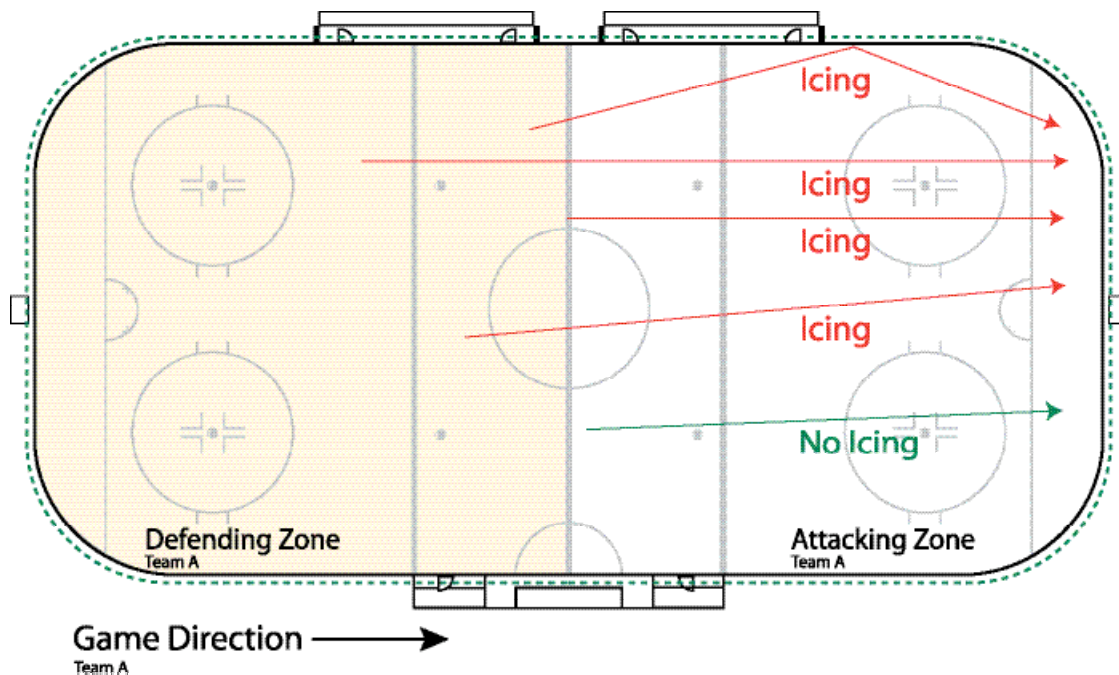
**905 - ICING THE PUCK**

- a) For the purpose of this rule, the centre red line divides the ice rink into two halves. The point of last contact with the puck by the team in possession shall be used to determine whether or not icing has occurred.
- b) Should a player of a team equal or superior in numerical strength shoot, bat or deflect the puck from his own half of the ice beyond the goal line of the opposing team, play shall be stopped and icing shall be called.

- c) A face-off shall take place at the end zone face-off spot of the offending team nearest to where they last touched the puck.
- d) No icing will be called:
1. If the puck enters the goal
    - the goal is allowed,
  2. If the offending team is **"Short Handed"** at the instant the puck is shot,
  3. If the puck touches any part of an opposing player, including the goalkeeper, before crossing the goal line,
  4. If the puck is iced directly from a player participating in a face-off,
  5. If, in the opinion of the Linesman, any player from the opposing team, except the goalkeeper, is able to play the puck before it crosses the goal line,
  6. Once the goalkeeper leaves his goal crease or when the goalkeeper is outside his goal crease during icing situation and moves in the direction of the puck.
- A. If the Linesmen have made a mistake in calling an icing, the puck shall be faced-off on the centre ice face-off spot.
- B. The purpose of this section is to enforce continuous action and both Referee and Linesmen shall interpret and apply the rule to produce this result.
- C. **"Short Handed"** means that due to a penalty(s), the team shall be below the numerical strength of its opponents on the ice.

#### **906 - DEFINITION OF A GOAL**

- a) A goal shall be allowed:
1. When the puck has been put between the goal posts below the crossbar and entirely across the goal line by the stick of a player of the attacking team,
  2. If the puck has been put into the goal in any way by a player of the defending team,
  3. If the puck has been deflected into the goal from the shot of an attacking player by striking any part of a teammate,
  4. If a player of the attacking team has been physically interfered with, by the action of any defending player so as to cause him to be in the goal crease when the puck enters the goal, unless if in the opinion of the Referee, he/she had sufficient time to get out of the crease,
  5. If the puck should become loose in the goal crease and then put into in the goal by the stick of the attacking player,
  6. When the puck deflects directly off the sled of an attacking or defending player,
  7. If an attacking player is in the goal crease at the moment the puck crosses the goal line and in no way affects the goalkeeper's ability to make a save, unless the cases described in **Rule 907**.
  8. When the puck deflects directly off the goalkeeper's face mask.
- A. All such calls shall be made by the Referee and he/she may consult with the Linesmen and /or the goal judge.

**907 - DISALLOWING A GOAL**

- a) No goal shall be scored:
1. If an attacking player deliberately throws, bats with the hands or otherwise directs the puck by any means other than his stick into the goal even if the puck has been further deflected by any player, goalkeeper or official,
  2. If an attacking player contacted the puck with the stick above the normal height of the shoulder,
  3. If the puck has been directly deflected into the goal off an official,
  4. If an attacking player has any part of his sled or holds his stick in the goal crease when the puck enters the goal, unless he/she has been physically interfered with, by the action of any defending player so as to cause him to be in the goal crease when the puck enters the goal, unless if in the opinion of the Referee, he/she had sufficient time to get out of the crease, or unless **Rule 906** applies,
  5. If the goal has been displaced from its normal position, or the frame of the goal net is not completely flat on the ice,
  6. If an attacking player initiates contact with the goalkeeper, incidental or otherwise, while the goalkeeper is in his goal crease and a goal is scored,
  7. If an attacking player initiates any contact with the goalkeeper, other than incidental contact, while the goalkeeper is outside his goal crease and a goal is scored.
  8. Where an attacking player enters or takes a position within the goal crease so as to obstruct the goalkeeper's vision and impair his ability to defend his goal net and a goal is scored.
  9. Where a goalkeeper has been pushed into the goal together with the puck after making a stop. If applicable, appropriate penalties shall be assessed.
- b) Where the puck is under the player who is in or around the goal crease (deliberately or otherwise), a goal cannot be scored by pushing this player together with the puck into the goal. If applicable, the appropriate penalties shall be assessed, including the Penalty Shot (see **Rule 1046**).
1. No goal shall be disallowed after the face-off immediately following the scoring of that goal.
  2. The goal crease is defined as a volume, extending from the crease area on the ice up to **1.27m** above the ice surface.
  3. **"Contact"**, whether incidental or otherwise, between a goalkeeper and an attacking player may be with the stick or any part of the body.
  4. All such calls shall be based strictly on the judgement of the Referee.

**908 - GOAL AND ASSIST AWARDED TO THE PLAYER**

- a) A **"Goal"** shall be credited in the scoring records to the player who propelled the puck into the opponent's net.
- b) Each goal shall count one point in the player's record.
- c) When a goal has been scored, an **"Assist"** shall be credited to the player(s) taking part in the play immediately preceding the action.

- d) No more than two assists can be given to any goal.
- e) Each assist shall account for one point in the player's record.
  - 1. Only one point may be awarded to any one player on a goal.
  - 2. Two assists may be awarded when a player scores after a rebound off of the goalkeeper.
  - 3. In the case of an obvious error in awarding a goal or assist, the error shall be corrected promptly, but changes shall not be made once the Referee has signed the Official Game Sheet.

### **909 - PUCK OUT OF BOUNDS**

- a) When the puck goes outside the playing area or strikes any obstacles, other than the boards or protective glass above the ice surface, the play will be stopped and the face-off will take place at the nearest point on the imaginary line from where the puck was shot or deflected, unless expressly provided for in these rules.

### **910 - PUCK ON THE NET**

- a) When the puck is lodged in the outside netting of the goal for more than three seconds or held against the goal between opposing players, the Referee shall stop the play and a face-off shall take place:
  - 1. At the nearest end zone face-off spot.
  - 2. At the nearest neutral zone face-off spot if, in the opinion of the Referee, the stoppage has been caused by an attacking player.

### **911 - PUCK OUT OF SIGHT**

- a) Should a scramble take place or a player accidentally falls on the puck and the puck is out of sight of the Referee, he/she shall immediately stop the play, and the puck shall be faced-off at the point where the play has been stopped, unless provided for in the rules.

### **912 - Illegal Puck**

- a) If, at any time, while play is in progress, a puck other than the one legally in play shall appear on the playing surface, the play shall not be stopped until the play then in progress is completed by change of possession.

### **913 - PUCK STRIKING AN OFFICIAL**

- a) Play shall not be stopped because the puck touches an official except when the puck has entered the goal.

### **914 - STOPPING/ PASSING THE PUCK WITH HANDS**

- a) A player shall be permitted to stop or bat the puck in the air with the open hand or push it along the ice with his hand, unless in the opinion of the Referee, the player has deliberately directed the puck to a teammate:
- b) If a teammate of such a player obtains possession of the puck in the Neutral Zone, play shall be stopped and the puck faced-off at the location where the offense occurred,

unless the offending team gains a territorial advantage, then the face-off shall be where the stoppage of play occurred.

- c) If a teammate of such a player obtains possession of the puck in his Defending Zone, the Referee shall not stop the play provided the hand pass is completed before the player and the puck leave the zone.  
However, when the puck is passed with the hand from a player in the Neutral Zone to a teammate in his Defending Zone, the Referee shall stop the play with the face-off at the point of stoppage.
- d) If a teammate of such a player obtains possession of the puck in his Attacking Zone, the Referee shall stop the play with the face-off at the Neutral Zone face-off spot outside the Attacking Zone unless the puck was batted from the offending team's Defending Zone or anywhere in the Neutral Zone, in which case the face-off will take place from where the puck was batted.
- e) A goal shall be disallowed if the puck was batted by an attacking player even if deflected into the goal by any player, his stick, sled, goalkeeper or official into the goal.

#### **915 - HIGH STICKING THE PUCK**

- a) Stopping or batting the puck with the stick above the height of the shoulders is prohibited, and the play will be stopped, unless:
  - 1. The puck is batted to an opponent in which case the play shall continue and the Referee shall give the "Wash Out" signal.
  - 2. A player of the defending team bats the puck into his own goal, in which case the goal is allowed.
- b) If the puck has been high-sticked by an attacking player in his Attacking Zone the face-off shall take place at the nearest spot in the Neutral Zone unless the offending team gains a territorial advantage, then the face-off shall be where the stoppage of play occurred.
- c) If the puck has been high-sticked by a player in his Defending Zone or in the Neutral Zone the face-off shall take place where the offense occurred, unless the offending team gains a territorial advantage, then the face-off shall be where the stoppage of play occurred.
- d) No goal can be scored when the stick of an attacking player makes contact with the puck above the normal height of the shoulders.

#### **916 - INTERFERENCE BY SPECTATORS**

- a) In the event that objects are thrown on to the ice which interferes with the progress of the game, the Referee shall stop the play and the puck shall be faced-off at the spot the play was stopped.
- b) In the event of a player being held or interfered with by a spectator, the Referee or the

Linesman shall stop the play. If the team of the player interfered with is in possession of the puck, the play shall be allowed to be completed.



## SECTION 10 – PENALTIES

### 1000 - PENALTIES – DEFINITION AND PROCEDURES

Penalties are divided into the following categories showing time to be served:

1. MINOR PENALTY	(2)
2. BENCH MINOR PENALTY	(2)
3. MAJOR PENALTY	(5)
4. MISCONDUCT PENALTY	(10)
5. GAME MISCONDUCT PENALTY	(GM)
6. MATCH PENALTY	(MP)
7. PENALTY SHOTS	(PS)

All penalties shall be actual playing time.

1. Penalties imposed after the end of the game shall be reported by the Referee on the Official Game Sheet.
2. Some rules state that the Manager or Coach shall designate a player to serve a penalty. If they refuse to do so, the Referee has the authority to name any player of the offending team who was on the ice at the time of the penalty call to serve the penalty.
3. When the Minor or Major penalties of two players of the same team terminate at the same time, the Captain of that team shall designate to the Referee which player shall return on the ice first. The Referee will then instruct the Scorekeeper accordingly.
4. For a Game Misconduct penalty, a total of **20 minutes** shall be recorded against the penalized player.  
For a Match penalty, a total of **25 minutes** shall be recorded against the penalized player.
5. For all Game Misconduct, and Match penalties the Referee shall:

Report to the Proper Authorities immediately following the game.

### 1001 - MINOR PENALTY

- a) For a Minor penalty, any player, other than the goalkeeper, will be ruled off the ice for **(2)** two minutes and no substitution shall be permitted.

### 1002 - BENCH MINOR PENALTY

- b) For a Bench Minor penalty, any player, other than the goalkeeper, of the penalized team, designated by the Manager or the Coach through the Captain, will be ruled off the ice for **(2)** two minutes and no substitution shall be permitted.

Table of Penalties

Penalty	Players	Goalkeepers	Remarks	Coincidental-penalties			
	Player out for	Served on the penalty bench by	Goalkeeper out for	Served on the penalty bench by			
		Offender		Recorded on game sheet			
				Observation			
MINOR	2 Minutes	Offender	-	Player on the ice	2 Minutes	May expire on a goal	May apply
BENCH MINOR	2 Minutes	Any player	Not applicable	-	2 Minutes	May expire on a goal	May apply
MAJOR	Balance of the game	Any player except the offending for 5 minutes	Balance of the game	Player on the ice for 5 minutes	5 Minutes	-	May apply
MISCONDUCT	10 Minutes	Offender	-	Player on the ice	10 Minutes	-	-
GAME MISCONDUCT	Balance of the game	None	Balance of the game	None	20 Minutes	Report	-
MATCH	Balance of the game	Any player except the offending for 5 minutes	Balance of the game	Player on the ice for 5 minutes	25 Minutes	Report	May apply
PENALTY SHOT	-	-	-	-	PENALTY SHOT	-	-

- c) If, while a team is **“Short Handed”** because of one or more Minor or Bench Minor penalties, the opposing team scores a goal, the first of such penalties shall automatically terminate unless such penalty was assessed at the same time as an opposing player’s penalty which originally caused both teams to play one player short, in which case the next Minor or Bench Minor penalty assessed to the scored upon team shall terminate.
1. The designated player shall take his place on the penalty bench promptly and serve the penalty as if it was a Minor penalty imposed to him.
  2. **“Short Handed”** means that, due to a penalty(s), the team must be below the numerical strength of its opponents on the ice at the time the goal is scored.
  3. This rule does not apply when a goal is scored on a Penalty Shot.

### **1003 - MAJOR PENALTY**

- a) For a Major penalty, any player, including the goalkeeper, will be ruled off the ice for the balance of the game (**Game Misconduct penalty**) and substitution shall be permitted after **(5)** five minutes.
1. When a player is assessed a Major and a Minor penalty at the same time, the Major penalty shall be served first.
- This applies when both penalties are imposed on the same player (**see Rule 1012**).

### **1004 - MISCONDUCT PENALTY**

- a) For his first Misconduct penalty, any player, other than the goalkeeper, shall be ruled off the ice for **(10)** ten minutes and immediate substitution shall be permitted. The player whose Misconduct penalty has expired shall stay on the penalty bench until the next stoppage of play.
- b) For his second Misconduct penalty in one game, any player, including the goalkeeper, will automatically be ruled off the ice for the balance of the game (**Game Misconduct penalty**) and immediate substitution shall be permitted.
1. When a player is assessed a Minor or Major penalty and a Misconduct penalty at the same time, the penalized team shall immediately put a substitute player on the penalty bench to serve the Minor or Major penalty without change.

### **1005 - GAME MISCONDUCT PENALTY**

- a) For a Game Misconduct penalty, any player, including the goalkeeper or team official, shall be ruled off the ice and ordered to the dressing room for the balance of the game and immediate substitution for the player or the goalkeeper shall be permitted.
1. A Game Misconduct penalty does not incur automatic suspension, except for that game, but the Proper Authorities shall have the power to suspend the player or the team official from participating in further games.
  2. In championships and tournament games, any player or team official assessed his second Game Misconduct Penalty shall be automatically suspended for his team’s next championship or tournament game.

### **1006 - MATCH PENALTY**

- a) For a Match penalty, any player, including the goalkeeper, shall be ruled off the ice and

ordered to the dressing room for the balance of the game and substitution shall be permitted after five minutes.

1. A player or team official incurring a Match penalty shall be awarded an automatic further suspension, which means that he shall be suspended for the next game as a minimum, and his case shall be dealt with by the Proper Authorities.

### **1007 - PENALTY SHOT**

- a) Five conditions are required to award a Penalty Shot to a player being fouled from behind:
  1. The infraction shall take place when the puck is outside of the player's defending zone (completely across the blue line).
  2. The attacking player shall be in possession and have **"Control of the Puck"**.
  3. The infraction shall have been committed **"From Behind"**.
  4. The attacking player in possession and control of the puck shall have been denied a reasonable scoring opportunity.
  5. The player in possession and control of the puck shall have had no opposing players to pass other than the goalkeeper.
- b) If the infraction involves a Minor penalty, the Penalty Shot shall be taken and the penalty will not be assessed regardless of whether the Penalty Shot results in a goal or not.
- c) If the infraction involves any other penalty, the Penalty Shot shall be awarded and the penalty shall be assessed regardless of whether the Penalty Shot results in a goal or not.
  1. **"Control of the Puck"** is the act of propelling the puck with the stick. If the puck is touched by another player or his equipment while it is being propelled or hits the goal or goes free, the player shall no longer be considered to be in control of the puck.
  2. If, when the opposing goalkeeper has been removed from the ice and a player in **"Control of the Puck"** outside his own Defending Zone, with no opponent to pass between him and the opposing goal net (**see also Rule 1027**) is fouled from behind, the Referee shall award a Goal to the non-offending team.
  3. **"From Behind"** is determined by the position of the player's body and **not** by the position of the player's sled.

### **1008 - PENALTY SHOT PROCEDURE**

- a) The Coach or the Captain of the non-offending team selects and reports to the Referee the number of any non-penalized player who shall take the shot.
- b) The Referee shall cause to be announced the name and number of the player taking the Penalty Shot, who cannot be a player serving a penalty or have been assessed a delayed penalty.
- c) The players of both teams shall withdraw to the sides of the rink and behind the red line.
- d) The Referee shall place the puck on the center spot.

- e) Only a goalkeeper may defend against the Penalty Shot.
- f) The goalkeeper shall stay in his crease until the player has touched the puck.
- g) The player shall, on instruction of the Referee, play the puck and proceed towards his opponent's goal line and attempt to score on the goalkeeper.
- h) Once the puck is shot the play shall be considered complete, and no goal can be scored by a second shot of any kind.
- i) If a goal is scored, the face-off will take place at center ice.
- j) If no goal is scored, the face-off will take place at either of the end zone face-off spots in which the Penalty Shot has been attempted.
  1. The time required for taking a Penalty Shot will not be recorded in the actual playing time in any period.
  2. If the foul upon which the Penalty Shot is based occurred during actual playing time, the Penalty Shot will be awarded and taken immediately in the usual manner, notwithstanding any delay occasioned by a slow whistle by the Referee. In this case, the play shall be permitted to be completed, which delay results in the expiry of the regular playing time in any period.
  3. If the goalkeeper leaves his crease before the player has touched the puck, or commits any foul, the Referee shall raise his arm but allow the shot to be completed. If the shot fails, he shall permit the Penalty Shot to be taken again.

If the goalkeeper leaves the goal crease too early, the Referee shall:

1. Issue a Warning the first time and a new Penalty Shot.
2. Issue a Misconduct penalty the second time and a new Penalty Shot.
3. Award a Goal the third time.
4. The goalkeeper shall attempt to block the shot in any manner, except by throwing his stick or any other object, in which case a goal shall be awarded.
5. When the Penalty Shot is taken, if any player of the opposing team interferes or distracts the player taking the shot, and because of such action the shot fails, the Referee shall allow a second Penalty Shot and assess a Misconduct penalty on the offending player.

### **1009 - SUPPLEMENTARY DISCIPLINE**

- a) In addition to the suspension imposed under these rules, the Proper Authorities may, at any time after the conclusion of the game, investigate any incident and may assess additional suspensions for any offense committed on or off the ice at any time before during and after the game, whether or not such offenses have been penalized by the Referee.

### **1010 - GOALKEEPER PENALTY PROCEDURE**

#### **A goalkeeper never goes to the penalty bench**

- a) For Minor or first Misconduct penalties assessed to the goalkeeper:

1. The goalkeeper continues to play.
  2. His penalty shall be served by another player of his team who was on the ice at the time the play was stopped to assess the penalty for the infraction and was designated by the Manager or Coach through the Captain.
- b) For Major, Game Misconduct or Match penalties, the goalkeeper shall be ruled off the ice for the balance of the game.

He shall be replaced by the substitute goalkeeper, if available, or otherwise by a member of his team, who shall be permitted **10 minutes** to dress in the goalkeeper's full equipment.

- c) In the case of Major or Match penalties, the **5 minute** penalty shall be served by another player of his team who was on the ice at the time the play was stopped to assess the penalty for the infraction as was designated by the Manager or Coach through the Captain.
1. All penalties imposed to a goalkeeper, regardless of who serves the penalty, shall be charged in the records against the goalkeeper.
  2. Any additional penalties which were assessed to the goalkeeper at the same stoppage of play shall apply and shall be served by another player of his team who was on the ice at the time the play was stopped to assess the penalty for the infraction.

### **1011 - COINCIDENTAL PENALTIES**

- a) When an equal number of identical penalties (Minor, Major or Match) are assessed to both teams at the same stoppage of play, such penalties shall be known as:

#### **Coincidental Penalties**

- b) When such penalties are assessed, immediate substitutions shall be made for those penalties and they shall not be taken into account for the purpose of delayed penalties.
- c) In the case where the penalized players remain in the game, they shall take their place on the penalty bench and shall not leave until the first stoppage of play following the expiry of their respective penalties.

There is only one exception to this rule (see section 'd' of this rule):

- d) When both teams are at Full Strength on the ice, No Substitution shall be permitted if only one Minor penalty is assessed to one player on each team at the same stoppage of play.
1. In the application of this rule, Minor and Bench Minor penalties are considered as identical.

### **1012 - DELAYED PENALTY**

**This rule applies only when Minor, Bench Minor, Major or Match penalties are involved.**

- a) If a third player of any team is assessed a penalty while two players of his team are serving penalties, his penalty time shall not commence until the penalty time of one of the other players has elapsed.

- b) The player shall proceed at once to the penalty bench, but may be replaced on the ice by a substitute.
- c) When any team has three or more players serving penalties at the same time, and because of the delayed penalty rule a substitute for the third offender is on the ice, none of the three penalized players may return to the ice until play has been stopped, unless by reason of the expiration of his penalty the penalized team is allowed to have more than four players including the goalkeeper on the ice, in which case the penalized players will be permitted to return in the order of their penalties.
1. If the penalties of two players of the same team expires at the same time, the Captain of the team will designate to the Referee which of the players shall return to the ice first, and the Referee shall instruct the Scorekeeper accordingly.
  2. When a Major and a Minor penalty are imposed at the same time on two or more players of the same team, the Scorekeeper shall record the Minor penalty as being the first of such penalties.

This also applies when the two penalties are imposed on different players (see **Rule 1001**).

### **1013 - CALLING OF PENALTIES**

Should an infraction of the rules be committed which would call for a penalty:

- a) If the team of the offending player is in possession of the puck, the Referee shall immediately blow the whistle and assesses the penalty.

The face-off shall take place where the play was stopped, unless it was stopped in the offending team's attacking zone, in which case the face-off shall take place at the closest neutral zone face-off spot.

- b) If the team of the offending player is **NOT** in possession of the puck, the Referee shall raise his arm, signifying the calling of a penalty and, upon "**Completion of the Play**" by the team in possession, shall blow the whistle and assess the penalty.
- c) If, after the Referee has raised his arm signifying the calling of the penalty, a goal is scored in any manner against the non-offending team as a result of an action of that team, the goal shall be allowed and a penalty shall be imposed in a normal manner.
- d) If, after the Referee has raised his arm signifying the calling of the penalty, a goal is scored by the non-offending team, the goal shall be allowed and the first Minor penalty shall **NOT** be assessed. All other penalties shall be assessed. If the offending team is already short handed, the signalled Minor penalty shall be washed out but all penalties served in the penalty bench will remain.
- e) If after the Referee has signalled a penalty, but before the whistle has been blown, the puck enters the goal of the non-offending team as the direct result of the action of the player of the offending team, the goal shall not be allowed and the penalty signalled shall

be imposed.

- f) The face-off shall take place in the neutral zone near the blue line of the team shooting the puck where play was stopped unless, during the period of a delayed whistle due to a penalty by a player of the team not in possession, the side in possession ices the puck or shoots the puck from their defensive zone so that it goes out of bounds or is un-playable.

1. **“Completion of the Play”** by the team in possession means that the puck shall have come into the possession of, and have been controlled or intentionally directed by, a player or goalkeeper of the opposing team, or has been held.

No rebound off of any player of the opposing team, or off the goal or boards, will lead to completion of the play.

## FOULS AGAINST PLAYERS

### 1014 - BOARDING

- a) A player who body checks, elbows, or charges an opponent in such a manner that it causes the opponent to be thrown violently into the boards, shall be assessed, at the discretion of the Referee, a:

<b>Minor penalty</b>	<b>(2')</b>
or	
<b>Major penalty + Automatic Game Misconduct penalty</b>	<b>(5'+GM)</b>
or	
<b>Match penalty</b>	<b>(MP)</b>

- b) A player who injures his opponent as a result of boarding shall be assessed, at the discretion of the Referee, a:

<b>Major penalty + Automatic Game Misconduct penalty</b>	<b>(5'+GM)</b>
or	
<b>Match penalty</b>	<b>(MP)</b>

### 1015 - BUTT-ENDING

- a) A player who attempts to butt-end an opponent shall be assessed a:

<b>Double Minor penalty + Misconduct penalty</b>	<b>(2'+2'+10')</b>
--	--------------------

- b) A player who butt-ends an opponent shall be assessed, at the discretion of the Referee, a:

<b>Major penalty + Automatic Game Misconduct penalty</b>	<b>(5'+GM)</b>
or	
<b>Match penalty</b>	<b>(MP)</b>

- c) A player who injures his opponent by a butt-ending shall be assessed a:

<b>Match penalty</b>	<b>(MP)</b>
----------------------	-------------

1. **“Butt-ending”** identifies the act of a player who uses the shaft of the stick above the upper hand to check an opposing player.

2. **“Attempt to Butt-end”** shall include all cases when a butt-end gesture is made but no contact is made.

### **1016 - CHARGING**

a) A player who runs, charges, or intentionally causes his sled to leave the ice in an attempt to check an opposing player or goalkeeper shall be assessed, at the discretion of the Referee, a:

**Minor penalty** (2')

or

**Major penalty + Automatic Game Misconduct penalty** (5'+GM)

or

**Match penalty** (MP)

b) A player who injures his opponent as a result of charging shall be assessed, at the discretion of the referee, a:

**Major penalty + Automatic Game Misconduct penalty** (5'+GM)

or

**Match penalty** (MP)

1. **“Charging”** shall mean the action of a player who, as a result of distance traveled violently checks an opponent. Charging may be the result of a check into the boards, into the goal frame, or on open ice.

2. A player who makes physical contact with an opponent after the whistle has been blown, and if, in the opinion of the Referee, the player had sufficient time after the whistle to avoid such contact, shall be assessed, at the discretion of the Referee, a penalty for **“Charging”**.

3. A goalkeeper is not **“Fair Game”** just because he is outside of the goal crease area. A penalty for **“Interference”** or **“Charging”** shall be called in every case where an opposing player makes unnecessary contact with a goalkeeper.

### **1017 - CHECKING FROM BEHIND**

a) A player who runs, charges, or hits an opposing player from behind in any manner shall be assessed, at the discretion of the Referee, a:

**Minor penalty + Automatic Misconduct penalty** (2'+MP)

or

**Major penalty + Automatic Game Misconduct penalty** (5'+GM)

or

**Match penalty** (MP)

b) A player who injures an opponent as result of checking from behind shall be assessed a:

**Match penalty** (MP)

1. A **“Check From Behind”** is a check delivered on a player who is not aware of the impending hit, is unable to protect himself and contact is made on the back part of

the body.

2. However, if a player intentionally turns his body to create contact, this shall not be classified as a check from behind.

### **1018 - CHECKING TO THE HEAD AND NECK AREA**

a) A player who directs a check or blow, with any part of his body, to the head and neck area of an opposing player or **"drives"** or **"forces"** the head of an opposing player into the boards, shall be assessed, at the discretion of the Referee, a:

**Minor penalty + Automatic Misconduct penalty** (2'+MP)

or

**Major penalty + Automatic Game Misconduct penalty** (5'+GM)

or

**Match penalty** (MP)

b) A player who injures an opponent as result of checking to the head and neck area shall be assessed, a:

**Match penalty** (MP)

1. Blows to the head area during a fight or altercation are covered and are to be penalized under **Rule 1022** Fisticuffs or Roughing.

### **1019 - CROSS-CHECKING**

a) A player who cross-checks an opponent shall be assessed, at the discretion of the Referee a:

**Minor penalty** (2')

or

**Major penalty + Automatic Game Misconduct penalty** (5'+GM)

or

**Match penalty** (MP)

b) A player who injures an opponent by cross-checking shall be assessed, at the discretion of the Referee, a:

**Major penalty + Automatic Game Misconduct penalty** (5'+GM)

or

**Match penalty** (MP)

1. A **"Cross-check"** is a check delivered with both hands on the stick and no part of the stick on the ice.

### **1020 - ELBOWING**

a) A player who uses his elbow to foul an opponent shall be assessed, at the discretion of the Referee, a:

**Minor penalty** (2')

or

**Major penalty + Automatic Game Misconduct penalty** (5'+GM)  
 or  
**Match penalty** (MP)

b) A player who injures an opponent by elbowing shall be assessed, at the discretion of the Referee, a:

**Major penalty + Automatic Game Misconduct penalty** (5'+GM)  
 or  
**Match penalty** (MP)

### **1021 - EXCESSIVE ROUGHNESS**

a) Any player who commits an action not permitted by the rules that may cause or causes an injury to an opponent, to a team or game official shall be assessed a:

**Match penalty** (MP)

b) The circumstances shall be reported to the:

**Proper Authorities**

### **1022 - FISTICUFFS OR ROUGHING**

a) A player who intentionally takes off his glove/s in a fight or altercation shall be assessed a:

**Misconduct penalty** (10')

b) A player who starts fisticuffs shall be assessed a:

**Match penalty** (MP)

c) A player who, having been struck, retaliates with a blow or attempted blow, shall be assessed a:

**Minor penalty** (2')

d) Any player or goalkeeper who is the first to intervene in an altercation already in progress, shall be assessed in addition to any other penalties incurred in the incident a:

**Game Misconduct penalty** (GM)

e) If a player, after he has been ordered by the Referee to stop, continues the altercation, attempts to continue, or resists a Linesman in the discharge of his duties, he shall be assessed, at the discretion of the Referee, a:

**Double Minor penalty** (2'+2')

or

**Major penalty + Automatic Game Misconduct penalty** (5'+GM)

or

**Match penalty** (MP)

f) A player or team official who is on or off the ice and is involved in an altercation or fisticuffs with a player or team official off the playing surface, shall be assessed, at the discretion of the Referee, a:

**Misconduct penalty** (10')

or  
**Game Misconduct penalty** (GM)

or  
**Match penalty** (MP)

g) If a player is deemed guilty of unnecessary roughness, he shall be assessed, at the discretion of the Referee, a:

**Minor penalty** (2')

or

**Double Minor penalty** (2'+2')

or

**Major penalty + Automatic Game Misconduct penalty** (5'+GM)

h) A player who grabs or holds the face mask or helmet or pulls the hair of an opponent shall be assessed, at the discretion of the Referee, a:

**Minor penalty** (2')

or

**Major penalty + Automatic Game Misconduct penalty** (5'+GM)

### 1023 - HEAD-BUTTING

a) A player who attempts to or deliberately head-butts an opponent shall be assessed a:

**Match penalty** (MP)

1. "Attempt to Head-Butt" shall include all cases when a head-butting gesture is made but no contact is made.

### 1024 - HIGH STICKING

a) A player who carries or holds his sticks or any part of it above the height of his shoulders that makes contact with an opponent shall be assessed, at the discretion of the Referee, a:

**Minor penalty** (2')

or

**Major penalty + Automatic Game Misconduct penalty** (5'+GM)

or

**Match penalty** (MP)

b) A player who carries or holds his stick or any part of it above the height of his shoulders that makes contact with an opponent and causes an injury with the stick or any part of it to an opponent shall be assessed, at the discretion of the Referee, a:

**Major penalty + Automatic Game Misconduct penalty** (5'+GM)

or

**Match penalty** (MP)

c) However, if the high sticking action that caused the injury was judged accidental, the offending player shall be assessed a:

**Double Minor penalty** (2'+2')

**1025 - HOLDING AN OPPONENT**

- a) A player who holds an opponent or any part of his sled with his hands or stick or in any other way shall be assessed a:

**Minor penalty** (2')

**1026 - HOLDING THE STICK**

- a) A players who holds an opponent's stick with his hands or in any other way shall be assessed a:

**Minor penalty** (2')

**1027 - HOOKING**

- a) A player who impedes or seeks to impede the progress of an opponent by hooking him with his stick shall be assessed, at the discretion of the Referee, a:

**Minor penalty** (2')

or

**Major penalty + Automatic Game Misconduct penalty** (5'+GM)

or

**Match penalty** (MP)

- b) A player who injures an opponent by hooking shall be assessed at the discretion of the Referee:

**Major penalty + Automatic Game Misconduct penalty** (5'+GM)

or

**Match penalty** (MP)

- c) In a **"Breakaway"** situation, when a player in **"Control of the Puck"** outside his own defending zone has no opponent to pass other than the goalkeeper and he is hooked from behind, thus preventing a reasonable opportunity to score, the Referee shall award to the non-offending team, a:

**Penalty Shot**

- d) If, when the opposing goalkeeper has been removed from the ice, and the player in control of the puck outside of his own defending zone is hooked with no opposition between him and the opposing goal, thus preventing a reasonable opportunity to score, the Referee will immediately stop the play and shall award a:

**Goal**

1. A **"Breakaway"** shall be defined as situation when a player is in full control of the puck and has no opposing player between himself and the opposing goalkeeper, or goal if the goalkeeper has been removed.

2. **"Control of the Puck"** is the act of propelling the puck with the stick. If the puck is touched by another player or his equipment while it is being propelled and hits the goal or goes free, the player shall no be longer considered to be in control of the puck.

3. The Referee shall not stop the play until the attacking team has lost possession

of the puck.

4. The position of the puck shall be the determining factor. The puck must be fully outside the defending blue line to award a Penalty Shot or a Goal.

5. The intention of this rule is to restore a reasonable scoring opportunity which has been lost by reason of a foul from behind.

### **1028 - INTERFERENCE**

a) A player who interferes or impedes the progress of an opponent who is not in possession of the puck shall be assessed a:

**Minor penalty** (2')

b) A player on either the player's bench or the penalty bench who, by means of his stick or his body, interferes with the movement of the puck of any opponent on the ice during the progress of the play, shall be assessed a:

**Minor penalty** (2')

c) A player who, by means of his stick or his body, interferes with or impedes the progress of the goalkeeper while he is in his goal crease, shall be assessed a:

**Minor penalty** (2')

d) If, when the goalkeeper has been removed from the ice, any member of his team, including a team official, interferes by means of his stick, any other object, or his body, with the movement of the puck of an opposing player, the Referee shall award to the non-offending team a:

**Goal**

1. This rule applies to any interference action, such as:

- knocking a stick out of an opponent's hands,
- preventing a player who lost his stick to regain possession
- knocking or shooting any abandoned or broken stick or any object towards an opposing puck carrier.

2. The last player to touch the puck, other than a goalkeeper, shall be considered having possession of the puck.

3. If an attacking player deliberately stands in the goal crease, without interfering with the goalkeeper, the Referee shall stop the play and the ensuing face-off shall take place at the nearest face-off spot in the neutral zone.

### **1029 - SLASHING**

a) A player who impedes or seeks to impede the progress of an opponent by slashing with his stick shall be assessed, at the discretion of the Referee, a:

**Minor penalty** (2')

or  
**Major penalty + Automatic Game Misconduct penalty** (5'+GM)  
 or  
**Match penalty** (MP)

b) A player who injures an opponent by slashing shall be assessed, at the discretion of the Referee, a:

**Major penalty + Automatic Game Misconduct penalty** (5'+GM)  
 or  
**Match penalty** (MP)

c) A player who swings his stick at another player in the course of any altercation shall be assessed, at the discretion of the Referee, a:

**Major penalty + Automatic Game Misconduct penalty** (5'+GM)  
 or  
**Match penalty** (MP)

1. The Referee shall assess a slashing penalty to any player who swings his stick at an opponent without actually striking him, or makes a wild swing at the puck with the object of intimidating an opponent.

2. **"Tapping the stick"** of the puck carrier is not considered slashing if it is limited to hitting the stick for the sole purpose of taking the puck.

### **1030 - SPEARING**

a) A player who **"attempts to spear"** an opponent shall be assessed a:

**Double Minor penalty + Misconduct penalty** (2'+2'+10')

b) A player who spears an opponent shall be assessed, at the discretion of the Referee, a:

**Major penalty + Automatic Game Misconduct penalty** (5'+GM)  
 or  
**Match penalty** (MP)

c) A player who injures an opponent by spearing shall be assessed a:

**Match penalty** (MP)

1. **"Attempt to spear"** shall include all cases when a spearing gesture is made but no contact is made.

2. **"Spearing"** is the action of stabbing an opponent with the point of the stick blade, whether or not the stick is being carried with one or both hands.

### **1031 - TEEING**

a) A player who charges an opponent or who charges the opposing goalkeeper in his crease, using any part of the front radius of his sled shall be assessed, at the discretion of the Referee, a:

**Minor penalty** (2')

or	
<b>Major penalty + Automatic Game Misconduct penalty</b>	<b>(5'+GM)</b>
or	
<b>Match penalty</b>	<b>(MP)</b>

1. Teeing is defined as a player making contact with an opponent with any part of the front radius of his sled straight into an opponent.

## OTHER PENALTIES

### 1032 - ABUSE OF OFFICIAL AND UNSPORTSMANLIKE CONDUCT BY PLAYERS

a) If any player:

1. When penalized, does not go directly to the penalty bench or the dressing room.
2. While off the ice, uses obscene, profane or abusive language to any official, or any person.
3. While off the ice, interferes in any manner with any official. And the player is identifiable he shall be assessed a:

**Minor penalty** (2')

And the player is not identifiable his team shall be assessed a:

**Bench Minor penalty** (2')

b) A player who:

1. Challenges or disputes the ruling of any official during the game.
2. Intentionally shoots the puck out of reach of an official who is retrieving it.
3. Enters or remains in the Referee crease while the Referee is reporting to any official.

shall be assessed a:

**Misconduct penalty** (10')

For any further dispute, he shall be assessed a:

**Game Misconduct penalty** (GM)

c) If a player on the ice who:

1. Uses obscene, profane or abusive language on the ice or anywhere in the rink before, during or after the game except in the vicinity of the bench.
2. Bangs the boards with a stick or other object at any time.
3. Fails to go directly and immediately to the penalty bench following a fight or any altercation which he has been involved or causes any delay retrieving his equipment.
4. Persists to incite an opponent into occurring a penalty.

player shall be assessed a:

**Misconduct penalty** (10')

d) If a player on the ice persists in any course of conduct for which he has been previously assessed a Misconduct penalty, player shall be assessed a:

**Game Misconduct penalty** (GM)

e) A player who uses or makes any racial remark or ethnic slur shall be assessed a:

**Game Misconduct penalty** (GM)

f) Any player who:

1. Intentionally touches with hands or stick, holds or pushes or checks with hands, stick or body, trips, slashes, hits in any manner or spits at a game official.
2. Makes a travesty of or interferes with or is detrimental to the conducting of the game.
3. While on or off the ice or anywhere in the rink before, during or after the game makes any obscene gesture to any official or any person.
4. Spits at any person on the ice or anywhere in the rink.

player shall be assessed a:

**Match penalty** (MP)

g) If an identified player, who is off the ice, throws a stick or any other object onto the playing surface from the player's bench, player shall be assessed a:

**Minor penalty + Automatic Game Misconduct penalty** (2'+GM)

h) If an unidentified player, who is off the ice, throws a stick or any other object onto the playing surface from the player's bench, player shall be assessed a:

**Bench Minor penalty** (2')

1. To enforce this rule, the Referee has, in many instances, the following options:

1. Bench Minor penalty for violations occurring on or in the vicinity of the player's bench, but off of the playing surface and affecting non-playing personnel.
2. Misconduct penalty for violations occurring on the playing surface or in the penalty bench and where the penalized player is readily identifiable.

2. The player's gloves and stick or any other equipment shall be delivered to him at the penalty bench by a teammate.

### **1033 - ABUSE OF OFFICIALS AND UNSPORTSMANLIKE CONDUCT BY TEAM OFFICIALS**

a) If any team official:

1. Uses obscene, profane or abusive to any official or any person.
2. Interferes in any manner with any of the officials of the game.
3. Bangs the boards with a stick or other object at any time.

players team shall be assessed a:

**Bench Minor penalty** (2')

b) If player persists, or if player is guilty of any type of misconduct shall be assessed a:

**Game Misconduct penalty** (GM)

c) A team official who uses or makes any racial remark or ethnic slur shall be assessed a:

**Game Misconduct penalty****(GM)**

d) If any team official:

1. Holds or strikes an official.
2. Makes a travesty of or is detrimental to the conducting of the game.
3. Spits at a game official.

he shall be assessed a:

**Match penalty****(MP)**

e) If an identified team official throws a stick or any other object onto the playing surface from the player's bench he shall be assessed a:

**Game Misconduct penalty****(GM)**

and players team a:

**Bench Minor penalty****(2')**

f) If an unidentified team official throws a stick or any other object onto the playing surface from the player's bench, official shall be assessed a:

**Bench Minor penalty****(2')****1034 - BROKEN STICK**

a) A player or goalkeeper whose stick is broken shall not receive a stick thrown onto the ice, but may receive a stick from a teammate without proceeding to his player bench.

b) If a player whose stick is broken does not immediately drop the broken portions and continues to play, he shall be assessed a:

**Minor penalty****(2')**

c) A player with a broken stick may use the pick portion of the stick to propel himself to his bench for a replacement, while doing so the player must not participate in the play in any manner. If he participates in the play, he shall be assessed a:

**Minor penalty****(2')**

d) A goalkeeper may continue to play with a broken stick until the next stoppage of play or until goalkeeper has been legally provided with a new stick.

e) If the goalkeeper goes to the bench during a stoppage of play to replace his stick, and then returns back to resume play, he shall be assessed a:

**Minor penalty****(2')**

However, if the goalkeeper is changed for the substitute goalkeeper, no penalty shall be assessed.

f) The goalkeeper is allowed to go to the bench and change his stick when the play is in progress.

- g) If a player participates in the play while taking a replacement stick to a player or goalkeeper, he shall be assessed a:

**Minor penalty** (2')

1. A **"Broken Stick"** is one which, in the opinion of the Referee, is unfit for normal play.
2. A player without a stick may participate in the game.

### **1035 - CAPTAIN AND ALTERNATE CAPTAIN COMPLAINT**

- a) If the Captain or Alternate Captain comes to complain about a penalty, whether he was on the ice or he comes from the player's bench, he may at the discretion of the referee be assessed a:

**Misconduct penalty** (10')

### **1036 - DELAY OF GAME – ADJUSTMENT OF EQUIPMENT**

- a) Play shall not be stopped nor the game delayed by reason of repair or adjustments to player's equipment and uniform, and the player requiring such adjustments shall retire from the ice.
- b) Play shall not be stopped nor the game delayed by reason of repair or adjustments to goalkeeper's equipment and uniform, and the goalkeeper requiring such adjustments shall retire from the ice and the substitute goalkeeper shall take his place immediately.

- c) For any infraction to this rule the player or goalkeeper shall be assessed a:

**Minor penalty** (2')

### **1037 - DELAY OF GAME – DISPLACING THE GOAL FRAME**

- a) A player or goalkeeper who deliberately displaces the goal frame from its normal position shall be assessed a:

**Minor penalty** (2')

- b) If it happens during the last two minutes of the game, or at any time in overtime, by a defending player or goalkeeper in his Defending Zone the Referee shall award to the non-offending team a:

**Penalty Shot** (PS)

- c) If a player or goalkeeper deliberately displaces the goal frame from its normal position when an opponent is in control of the puck with no opposition between him and the goalkeeper, and with a reasonable opportunity to score, the Referee shall award to the non-offending team a:

**Penalty Shot** (PS)

- d) If a player of the defending team deliberately displaces the goal, and, in the opinion of the Referee, the puck would have entered the goal had it not been displaced, or if the defend-

ing team deliberately displaces the goal when the goalkeeper is off the ice thereby preventing an obvious and imminent goal, the Referee shall award to the non-offending team a:

**Goal**

**1038 - DELAY OF GAME – INJURED PLAYER REFUSING TO LEAVE THE ICE**

- a) An injured player who refuses to leave the ice shall be assessed a:  
**Minor penalty (2')**

**1039 - DELAY OF GAME – KEEPING THE PUCK IN MOTION**

- a) The puck must be kept in motion at all times. A team in possession of the puck in its own defending zone shall advance the puck towards the opposing goal except:
1. To carry the puck behind his goal once.
  2. If it is prevented to do so by players of the opposing team.
  3. If the team is short handed.
- b) A player beyond his Defending Zone shall not pass or carry the puck backward into his defending zone for the purpose of delaying the game, except when his team is short handed.

For the first infraction, the referee shall assess a:  
 Warning to the Captain of the offending team.

For the second infraction, during the same period, the offending player shall be assessed a:

**Minor penalty (2')**

- c) Any player or goalkeeper who holds or plays the puck with his stick, sled or body along the boards in such a manner to cause a stoppage of play, unless he is actually checked by an opponent, shall be assessed a:

**Minor penalty (2')**

**1040 - DELAY OF GAME – LATE LINE UP**

- a) If a team, after the end of an intermission, does not line up on the ice surface the required number of players to start a period (**or overtime**) the team shall be assessed a:

**Bench Minor penalty (2')**

**1041 - DELAY OF GAME – MORE THAN ONE CHANGE AFTER GOAL SCORED**

- a) If a team after scoring a goal has more than one change of players on the ice it shall be assessed a:

**Bench Minor penalty (2')**

**1042 - DELAY OF GAME – SHOOTING OR THROWING THE PUCK OUTSIDE THE PLAYING AREA**

- a) A player or goalkeeper who directly shoots, throws, or bats the puck with his hand or stick outside the playing area, shall be assessed a:

Minor penalty (2')

### **1043 - DELAY OF GAME – VIOLATION OF FACE-OFF PROCEDURES**

a) When a player has been removed from the face-off by an official and another player of the same team delays taking up his proper position after a **“Warning”**, the offending player shall be assessed a:

Minor penalty (2')

b) When a player not taking the face-off enters the face-off circle before the puck is dropped, the player of his team taking the face-off shall be removed and replaced. For the second violation during the same face-off, the offending player shall be assessed a:

Minor penalty (2')

### **1044 - DIVING**

a) Any player who, at the discretion of the Referee, embellishes an infraction, flagrantly imitates a fall, a reaction, or feigns an injury in an attempt to draw a penalty by his action, shall be assessed a:

Minor penalty (2')

### **1045 - ILLEGAL OR DANGEROUS EQUIPMENT**

a) A player or goalkeeper who:

1. Wears his equipment or facemask in a way that may cause an injury to an opponent.
  2. Wears any non-approved equipment.
  3. Uses or wears illegal or dangerous sleds, sticks or equipment.
  4. Does not wear his equipment, except gloves, head protection and goalkeeper leg guards, entirely under his uniform.
  5. A player who wears a glove in play from which all or part of the palm has been removed or cut to permit the use of a bare hand.
- shall be ruled off the ice and a **“Warning”** shall be issued to his team.

b) The Referee can request that a player or goalkeeper remove any personal accessories should the personal accessories worn during the game be regarded as dangerous for the player and other participants. If these accessories are difficult to remove, then the player or goalkeeper shall tape the personal accessories or put the item(s) safely under the jersey in such a way that they are no longer dangerous. In this case, the player or goalkeeper shall be ruled off the ice and a **“Warning”** shall be issued to his team.

1. The guilty player shall not be allowed to participate in the game until the illegal equipment has been corrected or removed.

c) For a second violation by any player or goalkeeper of the same team for any offense of this rule mentioned above, the Referee shall assess to the offending player or goalkeeper a:

Misconduct penalty (10')

d) If a player or goalkeeper refuses to surrender or destroys his stick or any part of his equip-

ment for measurement when requested by the Referee, this equipment shall be regarded as illegal and the player or goalkeeper shall be assessed a:

**Minor penalty + Misconduct penalty** (2'+10')

e) If a team has requested the measurement of any equipment of the opposing team and if the complaint is sustained the offending player shall be assessed a:

**Minor penalty** (2')

f) If a team has requested the measurement of any equipment of the opposing team and if the complaint is not sustained the team shall be assessed a:

**Bench Minor penalty** (2')

g) A player on the ice whose helmet comes off during play and who does not put the helmet back on with chin strap properly fastened, or does not return to his bench, and participates in the play in any manner shall be assessed a :

**Minor penalty** (2')

#### **1046 - FALLING ON THE PUCK BY A PLAYER**

a) If a player, other than the goalkeeper, deliberately falls on, holds or gathers the puck into his body, he shall be assessed a:

**Minor penalty** (2')

b) If, during the course of a face-off, a player deliberately falls on, gathers the puck into his body, or uses his body or sled to protect the puck from the opposing player, he shall be assessed a:

**Minor penalty** (2')

c) If a defending player, other than the goalkeeper, deliberately falls on, holds or gathers the puck into his body when the puck is in the goal crease of his team, the Referee shall award to the non-offending team a:

**Penalty Shot** (PS)

d) If the opposing goalkeeper has been removed from the ice and a player deliberately falls on, holds or gathers the puck into his body when the puck is in the goal crease of his team, the Referee shall award to the non-offending team a:

**Goal**

1.A player who drops on the ice to block a shot shall not be penalized if the puck is shot under him or becomes lodged in his clothing or equipment, but any use of the hands to make the puck un-playable shall be penalized.

#### **1047 - FALLING ON THE PUCK BY A GOALKEEPER**

a) If a player, other than the goalkeeper, deliberately falls on, holds or gathers the puck into his body, he shall be assessed a:

**Minor penalty** (2')

b) If a defending player, other than the goalkeeper, deliberately falls on, holds or gathers the puck into his body when the puck is in the goal crease of his team, the Referee shall award to the non-offending team a:

Penalty Shot (PS)

c) If the opposing goalkeeper has been removed from the ice and a player deliberately falls on, holds or gathers the puck into his body when the puck is in the goal crease of his team, the Referee shall award to the non-offending team a:

Goal

1. Goalkeeper is allowed to freeze the puck only when the goalkeeper's body remains at least partially in the goal crease.
2. Goalkeeper is allowed to freeze the puck only when he is pressured.
3. Goalkeeper is not allowed to freeze the puck

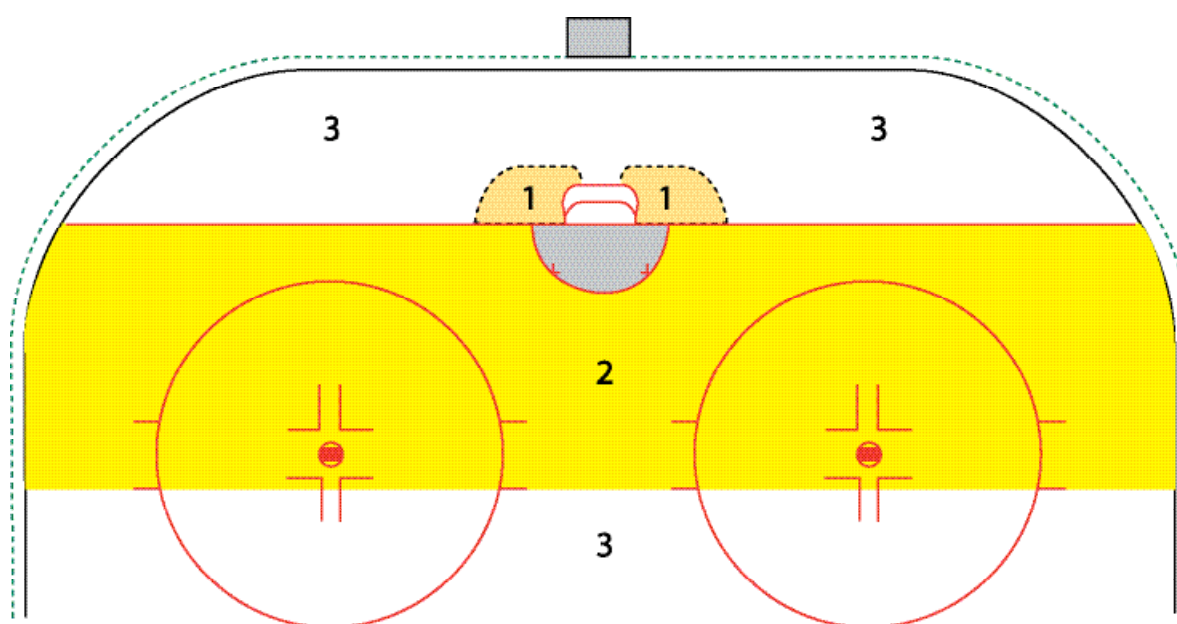

#### **1048 - HANDLING THE PUCK WITH HANDS BY A PLAYER**

a) Any player, except the goalkeeper, who closes his hand on the puck shall be assessed a:

Minor penalty (2')

b) Any player, except the goalkeeper, who picks up the puck from the ice with their hands shall be assessed a:

Minor penalty (2')

c) If any defending player, except the goalkeeper, picks up the puck with his hands from the ice in his goal crease, the Referee shall award to the non-offending team a:

Penalty Shot (PS)

d) If the goalkeeper is not on the ice as in section "c" of this rule, the Referee shall award to the non-offending team a:

Goal

1. A player is permitted to stop, bat or push the puck along the ice with his hands. However, **No Goal** shall be awarded if the puck was batted by an attacking player with the hand, even if it deflects off of any player or goalkeeper or the sticks of the players or goalkeeper of either team or official.

#### **1049 - HANDLING THE PUCK WITH HANDS BY A GOALKEEPER**

a) Unless he is being pressured, a goalkeeper who holds the puck more than three seconds shall be assessed a:

**Minor penalty** (2')

b) If a goalkeeper throws the puck forward and the puck is first played by a teammate, he shall be assessed a:

**Minor penalty** (2')

c) A goalkeeper who deliberately drops the puck into his pads, sled or any part of his equipment shall be assessed a:

**Minor penalty** (2')

1. The object of this rule is to keep the puck in play continuously and any action by the goalkeeper which causes an unnecessary stoppage of play shall be penalized.

#### **1050 - INFRINGEMENT OF CHANGE OF PLAYERS PROCEDURE**

a) Where a team attempts to make a player(s) change after its allotted period of time, the Referee shall send the player(s) back to the bench and issue a **"Warning"** to the team.

b) Any further infraction(s) of this procedure at any time during the course of the game shall be assessed to the offending team a:

**Bench Minor penalty** (2')

#### **1051 - INTERFERENCE WITH SPECTATORS**

a) A player who physically interferes with a spectator shall be assessed, at the discretion of the Referee, a:

**Match penalty** (MP)

#### **1052 - PLAYERS LEAVING THE PENALTY OR PLAYER'S BENCH**

a) Any player, other than as specified in **Rule 1054**, who leaves the penalty bench or player's bench and incurs a Minor, Major or Misconduct penalty for his actions, shall be automatically assessed a:

**Game Misconduct penalty** (GM)

b) If a player illegally enters the game and interferes with a player of the opposing team possession of the puck, who has no opponent between him and the goalkeeper, the Referee shall award to the non-offending team a:

**Penalty Shot** (PS)

c) If, when the opposing goalkeeper has been removed from the ice, a player illegally enters

the game and interferes with a player of the opposing team in possession of the puck, the Referee shall award to the non-offending team a:

### Goal

1. If a player shall illegally enter the game from his own player's bench or from the penalty bench by his own error or the error of the Penalty Bench Attendant, any goal scored by his own team shall be disallowed, while he is illegally on the ice, but all penalties imposed to both team shall be served.
2. If the player leaves the penalty bench because of an error of the Penalty Bench Attendant, he shall not be penalized but shall serve the remaining amount of time of his penalty when he re-entered the game.
3. The Penalty Bench Attendant shall note the time and advise the Referee at the first stoppage of play.

### 1053 - PLAYERS LEAVING THE PENALTY BENCH

- a) Except at the end of a period, a penalized player who leaves the penalty bench before his penalty time has expired shall be assessed a:

**Minor penalty** (2')

- b) If the violation occurs during a stoppage of play during an altercation, the offending player shall be assessed a:

**Minor penalty + Game Misconduct penalty** (2'+GM)

to be served at the expiration of his previous penalty.

- c) If a player serving a penalty on the penalty bench is to be changed after the penalty has been served, and does not proceed at once by way of the ice to his own player's bench before any change is made, his team shall be assessed a:

**Bench Minor penalty** (2')

- d) Any player who, having entered the penalty bench, leaves the penalty bench prior to the expiration of his penalty for the purpose of challenging an official's ruling, shall be assessed a:

**Minor penalty + Game Misconduct penalty** (2'+GM)

### 1054 - PLAYERS LEAVING THE BENCHES DURING AN ALTERCATION

- a) **No player shall leave the players or penalty bench at any time during an altercation.**

- b) The first player to leave the players or penalty bench during an altercation shall be assessed a:

**Double Minor penalty + Game Misconduct penalty** (2'+2'+GM)

- c) Any other player or players who leave(s) the players or penalty bench during an altercation shall be assessed a:

**Misconduct penalty****(10')**

1. Substitutions made prior to the altercation shall be permitted provided the players so substituting do not enter the altercation.
2. If players of both teams leave their respective benches at the same time, the first identifiable player of each team will be penalized under this rule.
3. For the purpose of determining which player was the first to leave his player's bench, the Referee shall consult the Linesmen and/or off-ice officials.
4. A **maximum** of five Misconduct and/or Game Misconduct penalties **per team** can be assessed under this rule.

**1055 - PREVENTION OF INFECTIONS BY BLOOD**

- a) A player bleeding or covered by blood of any player shall be considered as an injured player and shall leave the ice for treatment and/or cleaning. If he does not comply with this regulation he shall be assessed a:

**Minor penalty****(2')**

1. Such player shall be permitted to return to the ice surface provided that:
  1. The cut is completely closed and sealed with appropriate bandages.
  2. Any blood is removed from the player and his equipment and uniform replaced or properly cleaned.
2. If the ice surface, ice rink facilities or any objects are stained with blood, the Referee shall ensure that the bloodstains are removed by the rink personnel after the first stoppage of play.

**1056 - TEAM OFFICIALS LEAVING THE PLAYER'S BENCH**

- a) Any team official who goes on the ice during any period without the permission of the Referee shall be assessed a:

**Game Misconduct penalty****(GM)**

1. Where an injury has occurred to a player and there is a stoppage of play, a team doctor (**or designate**) may go on the ice to attend to the injured player.

**1057 - REFUSING TO START PLAY – TEAM ON THE ICE**

- a) If, when both teams are on the ice and one team refuses to play for any reason when ordered to do so by the Referee, the Referee shall warn the Captain and allow to the team so refusing 30 seconds to begin the game or resume play.

- b) If, at the end of that time the team still refuse to play, the Referee shall assess a:

**Bench Minor penalty****(2')**

- c) If there be a recurrence of the same incident, the Referee will declare the game forfeited to the non-offending team and the case shall be reported to the:

## Proper Authorities

### **1058 - REFUSING TO START PLAY - TEAM NOT ON THE ICE**

a) If a team, which is not on the ice, fails to go on the ice to start playing when ordered by the Referee through the Captain, Manager or Coach, the Referee shall allow to the refusing team two minutes to resume the game.

b) If the team resumes play within these two minutes, the Referee shall assess to the offending team a:

**Bench Minor penalty** (2')

c) If, at the end of that time the team still fails to go on the ice, the Referee shall declare the game forfeited to the non-offending team and the case shall be reported by the Referee to the Proper Authorities immediately after the game.

### **1059 - THROWING A STICK OR ANY OBJECT OUT OF THE PLAYING AREA**

a) Any player or goalkeeper who throws a stick or part of it, or any other object out of the playing area shall be assessed a:

**Game Misconduct penalty** (GM)

### **1060 - THROWING A STICK OR ANY OBJECT WITHIN THE PLAYING AREA**

**Note:** The position of the puck or puck carrier at the moment when a stick or any part of it, or any object is thrown, shot or directed (**with any part of the body**) by an opposing player in the direction of the puck or puck carrier is the determining factor whether to assess a Minor penalty or award a Penalty Shot. When the goalkeeper has been removed from the ice, refer to section e) of this rule.

a) Any player or goalkeeper on the ice or on the bench or team official, who shoots or throws a stick or any part of it, or any other object, or who directs (**with any part of the body**) a stick, any part of it, or any object in the direction of the puck or puck carrier in the Attacking Zone of his team, or in the Neutral Zone shall be assessed a:

**Minor penalty** (2')

b) If any player, goalkeeper or team official commits any of the actions described in section a) of this rule in his Defending Zone, the Referee shall award to the non-offending team a:

**Penalty Shot** (PS)

1. The position of the puck shall be the determining factor in this instance. The puck shall be fully outside the Defending Zone blue line in order to award a Penalty Shot or a Goal.

c) If the goalkeeper intentionally leaves his stick or any part of it, or any other object in front of his goal, and if the puck hits such objects while the goalkeeper is on or off the ice, the Referee shall award to the non-offending team a:

**Goal**

- d) If a stick or any part of it, or any object is thrown, shot or directed (with any part of the body) away by a player or goalkeeper on the ice and in no way interferes with the play, no penalty shall be assessed to the player or goalkeeper.
- e) When a player on the ice, or player/goalkeeper on the bench, or team official throws or shoots a stick, or any part of it, or any object, or who directs **(with any part of the body)** a stick, or any part of it, or any object in the direction of the puck or puck carrier in any zone when the goalkeeper has been removed from the ice, the Referee shall award the non-offending team a:

**Goal**

1. When a player or goalkeeper discards the broken portion of a stick by tossing it to the side of the rink (and not over the boards) in such a way not to interfere with play or an opposing player, no penalty shall be imposed for such action.

**1061 - THROWING A STICK OR ANY OBJECT ON A BREAKAWAY SITUATION**

- a) When a player in control of the puck outside his own Defending Zone, and having no opponent to pass other than the goalkeeper, and any member of the opposing team, including team officials, throws or shoots a stick, any part of it, or any other object or who directs **(with any part of the body)** a stick or any part of it, or any object in the direction of the puck or puck carrier, the Referee shall award to the non-offending team a:

**Penalty Shot**

**(PS)**

- b) When the actions described in section a) of this rule are committed against a player in control of the puck outside his own Defending Zone when the goalkeeper has been removed from the ice, the Referee shall award to the non-offending team a:

**Goal**

**1062 - TOO MANY PLAYERS ON THE ICE**

- a) If, at any time during play a team has more than the number of players on the ice to which they are entitled, the team shall be assessed a:

**Bench Minor penalty**

**(2')**

- b) If, in the last two minutes of the game and at any time in overtime a deliberate illegal substitution (too many players on the ice) is made, the Referee shall award to the non-offending team a:

**Penalty Shot**

**(PS)**

**1063 - PENALTIES FOR GOALKEEPER'S**

The procedures for goalkeeper penalties are outlined in **Rule 1010**.

Specific penalties for goalkeeper are outlined in the following rules:

- 1008                      Penalty Shot Procedure
- 1034                      Broken Stick
- 1037                      Displacing the Goal Frame
- 1039                      Keeping the Puck in Motion

- 1042 Shooting or Throwing the Puck Outside the Playing Area
- 1047 Falling on the Puck
- 1049 Handling the Puck with Hands
- 1059 to 1060 Throwing a Stick or Any Object
- 1064 Goalkeeper Beyond the Center Red Line
- 1065 Goalkeeper Going to the Player's Bench During Stoppage of Play
- 1066 Goalkeeper Leaving the Goal Crease During an Altercation
- 1067 Goalkeeper Dropping the Puck on the Goal Netting

#### **1064 - GOALKEEPER BEYOND THE CENTER RED LINE**

- a) If a goalkeeper participates in the play in any manner when he is beyond the center red line, he shall be assessed a:

Minor penalty (2')

1. The position of the player's blades shall be the determining factor for the purpose of this rule.

#### **1065 - GOALKEEPER GOING TO THE PLAYER'S BENCH DURING STOPPAGE OF PLAY**

- a) If a goalkeeper goes to the player's bench without the permission of the Referee, during a stoppage of play, except to be replaced or during a time out, he shall be assessed a:

Minor penalty (2')

#### **1066 - GOALKEEPER LEAVING THE CREASE DURING AN ALTERCATION**

- a) If a goalkeeper leaves the immediate vicinity of his crease during an altercation, unless directed to do so by the Referee, he shall be assessed a:

Minor penalty (2')

#### **1067 - GOALKEEPER DROPPING THE PUCK ON THE GOAL NETTING**

- a) If a goalkeeper drops the puck on the goal netting to cause a stoppage of play he shall be assessed a:

Minor penalty (2')

#### **1068 - PROTECTION OF GOALKEEPER**

- a) In all cases which an attacking player initiates any intentional contact with the goalkeeper when the goalkeeper is inside his goal crease and whether or not a goal is scored, the attacking player shall be assessed the appropriate penalty.

- b) A goalkeeper is **NOT "fair game"** just because he is outside of the goal crease. The penalty shall be assessed in every case where an attacking player makes unnecessary contact with the goalkeeper (**see Rule 1016**). Incidental contact shall be permitted when the goalkeeper is in the act of playing the puck outside his goal crease provided the attacking player made a reasonable effort to avoid unnecessary contact.

- c) Where a goalkeeper has played the puck outside his goal crease and is then prevented from returning to his crease due to the action of an attacking player other than incident-

tal, such a player shall be assessed the appropriate penalty.

d) A goalkeeper shall be penalized if, by his actions outside the crease, he interferes with an attacking player who is attempting to play the puck or an opponent.

1. All calls concerning this rule shall be based strictly on the judgement of the Referee.

2. **"Contact"** whether incidental or otherwise between the goalkeeper and an attacking player may be with a stick or any part of the body.

3. If an attacking player has been pushed, shoved or fouled by a defending player so as to cause him to come into contact with the goalkeeper, such contact shall not be deemed to be initiated by the attacking player, provided the attacking player has made a reasonable effort to avoid such contact with the goalkeeper.

4. However, where an attacking player stands in the goal crease, play shall be stopped and a face-off shall take place in the nearest face-off spot in the Neutral Zone.

## SECTION 11 - REFEREES AND LINESMEN SIGNALS

### REFEREE SIGNALS

#### BOARDING - RULE 1014

Striking the clenched fist of one hand into the open palm of the opposite hand in front of the chest.



#### BUTT-ENDING - RULE 1015

A cross motion of the forearms, one moving under the other. Upper hand is open and the lower hand a clenched fist.



#### PLAYER CHANGE SIGNAL - RULE 705

The Referee allows a ten second period to the visiting team to make a player(s) change. After the ten seconds, the Referee will raise his arm which indicates that the visiting team may no longer change any player and the home team has ten seconds to change players.



#### CHARGING - RULE 1016

Rotating clenching fists around one another in front of the chest.



**CHECKING FROM BEHIND - RULE 1017**

A forward motion of both arms, with the palms of the hands open and facing away from the body, fully extended from the chest at shoulder level.



**CROSS-CHECKING - RULE 1019**

A forward and backward motion of the arms with both fists clenched, extending from the chest for a distance of about a half a meter.



**DELAYED CALLING OF PENALTY - RULE 1012**

Extended the non-whistle arm fully above the head. It is acceptable to point at the player once and then extend the arm above the head.



**ELBOWING - RULE 1020**

Tapping either elbow with the opposite hand.



**PUCK IN THE NET - RULE 906**

A single point directed at the goal in which the puck legally entered.

**HAND PASS - RULE 914**

Use open palm of hand in a pushing motion.

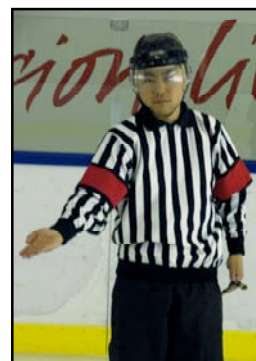
**HIGH STICKING - RULE 1024**

Holding both fists clenched, one immediately above the other at the height of the forehead.

**HOLDING - RULE 1025**

Clasping either wrist with the other hand in front of the chest.



**HOLDING THE STICK - RULE 1026**

Two stage signal followed by a signal indicating you are holding onto a stick with two hands in a normal manner.



**HOOKING - RULE 1027**

A tugging motion with both arms as if pulling something from in front towards the stomach.



**INTERFERENCE - RULE 1028**

Crossed arms with closed fists stationary in front of the chest.



**MATCH PENALTY - RULE 1006**

Patting the flat of the hand on top of the head.

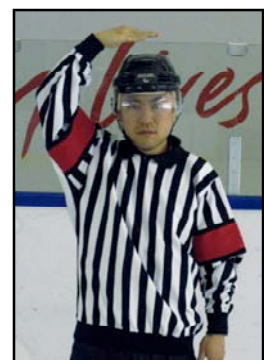

**MISCONDUCT PENALTY - RULES 1004, 1005**

Both hands on hips. The same signal for unsportsmanlike conduct, ten minute Misconduct, Game.

**PENALTY SHOT - RULE 1008**

Arms crossed above the head. Give the signal upon stoppage of play.

**ROUGHING - RULE 1022**

Fist clenched and arm extended out to the side of the body.

**SLASHING - RULE 1029**

A chopping motion with the edge of one hand across the opposite forearm.



**SPEARING - RULE 1030**

Jabbing motion with both hands thrust out immediately in front of the body and then hands dropped to the side of the body.



**TEEING - RULE 1031**

Striking the clenched fist of one hand into the fore arm of the opposite arm in front of the chest.



**TIME OUT - RULE 602**

Using both hands to form a "T" in front of the chest.

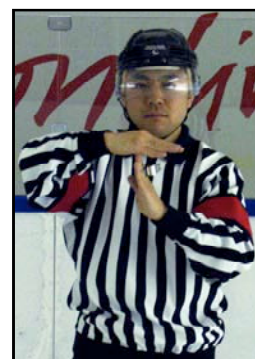

**TOO MANY PLAYERS ON THE ICE - RULE 1062**

Indicate with six fingers (one hand open) in front of the chest.



**CHECKING TO THE HEAD AND NECK AREA - RULE 1018**

The side movement of the open palm of the hand towards the side of the head.

**WASH OUT**

A sweeping sideways motion of both arms across the front of the body at the shoulder level with palms down:

- by the Referee to signal "no goal", "no hand pass", "no high sticking the puck".

- by the Linesman to signal "no icing" and, in certain situations, "no offside".

**LINESMAN'S SIGNALS****DELAYED OFFSIDE - RULE 904**

Non-whistle arm fully extended above the head. to nullify a delayed offside the Linesman shall drop the arm to the side.

**ICING THE PUCK - RULE 905**

The back Linesman (or Referee in the two-man system) signals a possible icing by fully extending either arm over his head. The arm should remain raised until the front Linesman or Referee, either blows the whistle to indicate an icing, or until the icing is washed out. Once the icing has been completed, the back Linesman or Referee will first cross his arms in front of the chest and then will point to the appropriate face-off spot and skate to it.



**OFFSIDE CALL - RULE 903**

The official will first blow the whistle and then point toward the blue line.



## ANNEX 1 - ILLUSTRATION OF GOAL FRAME

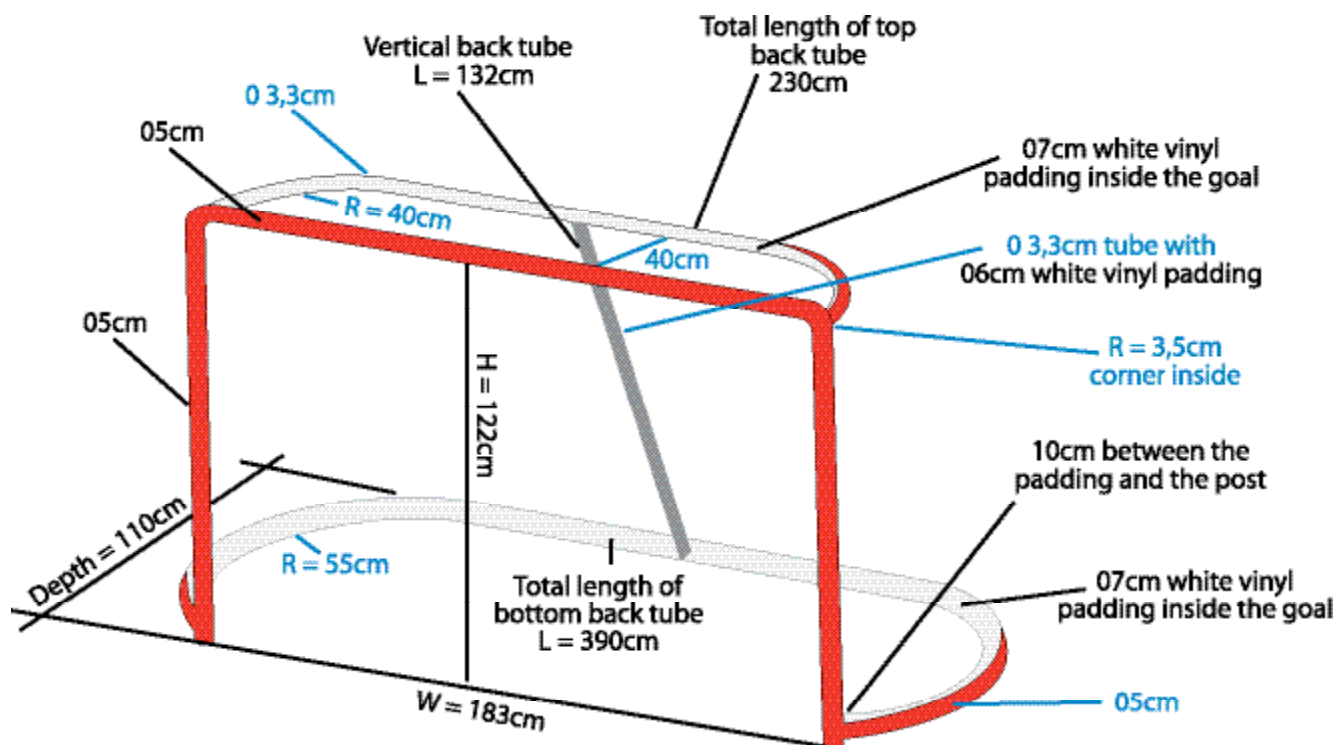

## ANNEX 2 - MAJOR RULE DIFFERENCES

### OVERVIEW

The purpose of this document is to introduce existing able-bodied hockey officials to the sport of sledge hockey. Although sledge hockey is basically the same game as able-bodied hockey, there are obvious differences and some subtle differences in the rules and in the way the game is played and officiated.

The IPC (International Paralympic Committee) Sledge Hockey Rule Book was derived from the IIHF 2006-2010 Rule Book with adaptations made for the sport of sledge hockey. Officials who work IIHF should have an easier time adapting to this Rule book than North American officials.

Outlined in this document are the major rule differences, positioning differences, and other miscellaneous differences.

### A 2.1 - RULE DIFFERENCES

For obvious reasons, the tripping and kneeling penalties have been removed from the rule-book.

**Rule 1031 – Teeing:** was added to the rule book as this could not happen in able-bodied hockey. Teeing is defined as “a player making contact with an opponent with any part of the front radius of his sled straight into his opponent.” This does not include all occurrences of contact being made, rather when contact is made at, or almost at right angles of the sleds with significant impact. This is a safety issue for the players as serious injuries can occur.

**Rule 1025 – Holding an Opponent:** is probably the most common penalty called in sledge hockey. Holding an opponent for even a moment can cause this player to lose any momentum he may have. Holding can occur on the arms, on the sled, anywhere on the body, on the head, and even on the opponent's stick.

**Rule 1015 – Butt-Ending:** can be extremely dangerous as there are sharp "picks" at the end of a player's stick. These "picks" are used by the players to propel themselves along the ice but are sometimes used as a "weapon". Officials should be very alert to a player's use of their sticks.

**Rule 1046 (b) – Falling on the Puck by a Player:** Often on face-offs, a player will intentionally fall on the puck in order to protect the puck from the opposing centre before passing the puck back to a team mate. This should be strictly enforced with the appropriate minor penalty.

**Rule 902 (b) Note 2 – Face-Offs:** This will not be new to IIHF officials but North American officials should take note that face-offs in the end zones will only take place at the end zone face-off spots, regardless of where the puck was deflected out of bounds.

**Rule 903 – Offsides:** The determining factors for an offside are 1. The position of the puck and 2. The position of the player's blades. The player must have the blades under his sled making contact with the blue line at the moment the puck crosses the line.

**Rule 1007 – Penalty Shot:** This rule is the same as the IIHF rule book with the exception of Note 3 which is the definition of "From Behind". "From Behind" is determined by the position of the player's body and not by the position of the player's sled. Even if the player's sled has come somewhat alongside his opponent's sled, if his body is still behind his opponent's, then the penalty shot shall be awarded.

**Rule 705 (b) – Change of Players Procedure During Stoppage of Play:** Because players are on sleds, 10 seconds is given to the visiting team and the home team to make their player changes instead of the normal 5 seconds. The linesman conducting the face-off will still allow the normal 5 seconds before dropping the puck.

**Rule 902 (b) – Procedure for Conducting Face-Off:** "The players shall be positioned squarely facing the sideboards of the rink, with their sleds outside of the face-off spot, and with the blade of their stick on the ice on the white part of the face-off spot." The centermen may face the same way as their opponent or in the opposite direction. After dropping the puck for a face-off, be very aware of the wingers behind you before attempting to back out.

## **A 2.2 - POSITIONING PROCEDURES, AND JUDGEMENT**

**Staying on top of the Play:** Referees should not hesitate to cross behind the goal net to get closer to the play. When players are battling for a loose puck at close quarters, there are a number of things that can happen including holding (this could be holding the opponent or the opponent's sled) and jabbing an opponent with the pick end of the stick. Because the players are low to the ice surface while sitting in their sleds, hands and sticks can be hidden

behind their opponents so the referee needs to be right on top of the play. This also applies to when the play progresses down the ice. For example, if you see a breakout pass from the end zone in your corner to a breaking player on the other side of the ice, feel free to cross over through the neutral zone to stay on top of the play.

**Moving out from the boards:** The referee has to find open ice during a breakout and when play is moving through the neutral zone. Players on sleds take up more room than able-bodied players so the referee should not be afraid to move away from the boards and move closer to the center in order to get out of the zone.

**Line change procedure:** When conducting a line change procedure in the end zones, the referee should move out from the end zone corners and make themselves seen by the benches to see if anyone is coming.

**Face-Offs:** Officials should conduct the face-off by holding the puck out over the face-off circle at the players' eye level. We do not want the players having to look up to anticipate when the official is going to drop the puck.

**Body Checks:** When a player body checks an opponent as they pass each other in opposite directions, the body check must be delivered with the shoulder. Often, a player will put out an elbow or a forearm to deliver the check and this should be penalized as this has a "clothesline" effect on the player who was checked.

**Judgement on icing's:** Linesmen must use a different sense of judgement when washing out an icing because he/she feels that a defending player (other than the goalkeeper) is able to play the puck before it crosses the goal line. A player on a sled is not able to move as quickly as an able-bodied player so use the appropriate judgement.

**Skating Backwards:** It is imperative that you are aware of players behind you before you proceed to back up. If you run into a player on a sled while skating backwards you will end up on top of the player and hurting that player and/or yourself.

**Linesmen standing outside the blue line:** Linesmen need to be aware that while play is in the attacking zone, defensemen sometimes curl back out into the neutral zone and come back into the attacking zone along the boards. Linesmen will have to give the defenseman room along the boards by either moving back further into the neutral zone or moving out from the boards to give him room.

**Never, ever jump!** Officials should never jump and they should take the hit and do everything possible not to fall on top of the players. Officials should never jump up on the boards, as the skate blades would then be at the head level of the players.

**Team benches on the ice:** When a game is played at an arena that does not support sleds on the team bench, the players are to sit along the boards in front of the team bench, between the blue line and the centre red line. Penalized players are to sit on the ice in the referee's

crease. If a puck is directed toward the team or penalty benches, the players are supposed to direct the puck as if it “bounced” off the boards. If the puck enters the team bench or if a player has directed the puck in an unfair manner, then blow the play right away. This is a safety issue, as there shouldn’t be players fighting for a loose puck among the players on the “bench”.

### ANNEX 3 - PROTECTIVE EQUIPMENT

The following is a current list of approved players and Goalkeeper's equipment. All infractions related to the wearing of equipment will be penalized under **Rule1045**.

#### Player Equipment:

Elbow Pads; Gloves; Throat Protectors; Shoulder Pads and Shin Protectors.

CCM	Eagle	Easton	Ferland (DR)	Graf
Hespeler	Mission Itech	Montreal	Nike Bauer	Pallas
Reebok	Sherwood	TPS Louisville		

#### Goalkeeper's Equipment:

Arm and Body; Blocker Glove; Catching Glove; and Mask.

Brian's	Brown	CCM	Eagle	Eddy
Heaton	Mission Itech	Montreal	Nike Bauer	Reebok
Sherwood	TPS Louisville	Vaughn		

## INDEX

---

<b>Item</b>	<b>Rule N°</b>
Abuse of Official by Players	1032
Abuse of Official by Team Officials	1033
Accessories and Foot protection	Section 3
Athletes on the Ice	702
Bench Minor Penalty	1002
Benches	204
Blue Lines	210
Blocking Glove	409
Boards	202
Boarding	1014
Broken Stick	1034
Butt-Ending	1015
Calling of Penalties	1013
Captain and Alternate Captain Complaint	1035
Center Line	211
Centre Face-Off Spot and Circle	213
Change of Players and Goalkeeper's From the Team Bench During Play	704
Change of Players Procedure During Stoppage of Play	705
Change of Players From the Penalty Bench	706
Change of Goalkeeper's During Stoppage of Play	707
Charging	1016
Checking From Behind	1017
Checking to the Head and Neck Area	1018
Clock	225
Clothing	Section 3, 4
Competition Equipment	Section 5
Coincidental Penalties	1011
Curve (of a stick)	306, 406
Cross-Checking	1019
Definition of the Field of Play	200
Definition of a Goal	906
Determining the Outcome of the Game	603
Delay of Game – Adjustment of Equipment	1036
Delay of Game – Displacing the Goal Frame	1037
Delay of Game – Injured Player Refusing to Leave the Ice	1038
Delay of Game – Keeping the Puck in Motion	1039
Delay of Game – Late Line Up	1040
Delay of Game – More Than One Change After Goal Scored	1041
Delay of Game – Shooting or Throwing the Puck Outside the Playing Area	1042
Delay of Game – Violation of Face-Off Procedures	1043
Delayed Offside Procedure	904
Delayed Penalty	1012

Dimensions of the Rink	201
Disallowing a Goal	907
Diving	1044
Division and Marking of the Surface	208
Doors	205
Elbow Pads	316
Elbowing	1020
Eligibility	Section 1
End Zone Face-Off Spots and Circle	215
End Zone Nets	207
Excessive Roughness	1021
Face-Offs	900
Face-Off Spots and Circles	212
Face-Off Spots and Imaginary Line	901
Face-Off Spots in Neutral Zone	214
Falling on the Puck by a Player	1046
Falling on the Puck by a Goalkeeper	1047
Field of play specifications	Section 2
Fisticuffs or Roughing	1022
Foot Guard/ Support	303, 403
Foot Protection	304, 404
Fouls Against Players	Section 10
Front Skid	302, 402
Full Face Masks	311
Game Format	Section 6
Game Misconduct Penalty	1005
Game Winning Penalty Shots	605
Gloves	312
Glass	206
Goal and Assist Awarded to the Player	908
Goal Crease	217
Goal Frames, Posts and Netting (Goal Net)	218
Goal Judges' Bench	221
Goal Lines	209
Goal (Net)	218
Goalkeeper's Equipment (Mobility Devices), Protective Clothing, Accessories and Foot protection	Section 4
Goalkeeper's Beyond the Center Red Line	1064
Goalkeeper's Clothing	410
Goalkeeper's Dropping the Puck on the Goal Netting	1067
Goalkeeper's Gloves	408
Goalkeeper's Going to the Player's Bench During Stoppage of Play	1065
Goalkeeper's Helmet and Full Face Mask	411
Goalkeeper's Sledge Frame	400
Goalkeeper's Seat	406

Goalkeeper's Sticks	407
Goalkeeper Leaving the Crease During an Altercation	1066
Goalkeeper's Leg Guards	412
Goalkeeper Penalty Procedure	1010
Handling the Puck With Hands by a Goalkeeper	1049
Handling the Puck With Hands by a Player	1048
Head-Butting	1023
Heel Support	301, 401
Helmet	310
High Sticking the Puck	915
High Sticking	1024
Hockey Stick	307
Holding an Opponent	1025
Holding the Stick	1026
Hooking	1027
Ice Cleaning	804
Ice Rink	Section 2
Icing the Puck	905
Illegal or Dangerous Equipment	1045
Illegal Puck	912
Illustration of Goal Frame	Annex 1
Injured Goalkeeper's	802
Injured Players	801
Interference by Spectators	916
Infringement of Change of Players Procedure	1050
Interference With Spectators	1051
Kick Plate	203
Linesman's Signals	Section 11
Major Rule Differences	Annex 2
Major Penalty	1003
Match Penalty	1006
MEASUREMENT Tools	Section 3, 4
Minimum Disability Requirement	100
Minor Penalty	1001
Misconduct Penalty	1004
Mouth Guard	314
Offsides	903
Other Penalties	Section 10
Overtime Period	604
Overview	Annex 2
Penalties	Section 10
Penalty Benches	220
Penalties – Definition and Procedures	1000
Penalties for goalkeeper's	1063
Penalty Shot	1007

Penalty Shot Procedure	1008
Pick MEASUREMENT Tool	319
Protective Glass	206
Player Equipment, Clothing, Protective Equipment	Section 3
Player Equipment (Mobility Devices)	Section 3
Playing Rules	Section 9
Players Leaving the Penalty or Player's Bench	1052
Players Leaving the Penalty Bench	1053
Players Leaving the Benches During an Altercation	1054
Prevention of Infections by Blood	1055
Procedure for Conducting Face-Offs	902
Protection of goalkeeper	1068
Protective Equipment	Annex 3
Protective Equipment (Accessories and Foot Protection)	Section 3, 4
Prevention of Infections	803
Positioning, Procedures and Judgement	A 2.2
Puck	501
Puck on the Net	910
Puck out of Bounds	909
Puck out of Sight	911
Puck Striking an Official	913
Red and Green Lights	226
Rink Lighting	229
Referee and Linemen Signals	Section 11
Referee Crease	216
Referee Signals	Section 11
Refusing to Start Play - Team Not on the Ice	1058
Refusing to Start Play – Team on the Ice	1057
Rule Differences	A 2.1
Safety	Section 8
Scorekeeper's Bench	222
Shin Protection	314
Shoulder Pads	317
Signal and Timing Devices	223
Siren	224
Skate Blades/ Blade Carrier	305, 405
Slashing	1029
Sledge Frames	300
Sledge Height MEASUREMENT Tool	318
Sledge Seat (Bucket)	306
Spearing	1030
Start of Game and Periods	601
Sticks, and Picks	308
Stopping/ Passing the Puck with Hands	914
Substitution of Players and Goalkeeper's	703

Supplementary Discipline	1009
Team Benches	219
Team Captain	701
Team Composition and Players in Uniform	700
Team Officials Leaving the Player's bench	1056
Teams	Section 7
Teeing	1031
Throat Protector	313
Throwing a Stick or Any Object on a Breakaway Situation	1061
Throwing a Stick or Any Object Out of the Playing Area	1059
Throwing a Stick or Any Object Within the Playing Area	1060
Time-Out	602
Timing of Game	600
Too Many Players on the Ice	1062
Uniforms	309
Unsportsmanlike Conduct by Players	1032
Unsportsmanlike Conduct by Team Officials	1033





International Paralympic Committee  
Adenauerallee 212-214  
53113 Bonn, Germany

Tel. + 49-228-2097-200  
Fax. + 49-228-2097-209  
info@paralympic.org

[www.paralympic.org](http://www.paralympic.org)

© 2008 International Paralympic Committee  
Photo: Yoshimura Moto